

Loadcenters & Circuit Breakers

3

Contents

<i>Description</i>	<i>Page</i>
Type CH Loadcenters and Circuit Breakers	
Product Description	3-2
Application Description	3-3
Standards and Certifications	3-3
Features, Benefits and Functions	3-5
Product Specifications	3-6
Product Selection	3-8
Loadcenters	3-8
Spa Panels	3-15
Surge Loadcenter	3-18
Renovation Loadcenter	3-20
CH Retrofit Interior Kits	3-21
Loadcenter Accessories	3-23
Circuit Breakers	3-29
Circuit Breaker Accessories	3-36
Technical Data and Specifications	3-38
Type BR Loadcenters and Circuit Breakers	
Product Description	3-40
Application Description	3-41
Standards and Certifications	3-41
Features, Benefits and Functions	3-42
Product Specifications	3-43
Product Selection	3-45
Loadcenters	3-45
Catalog Numbering System	3-46
Spa Panels	3-55
Riser Panels	3-59
BR Retrofit Interior Kits	3-60
Renovation Loadcenters	3-62
Loadcenter Accessories	3-63
Circuit Breakers	3-65
Circuit Breaker Accessories	3-75
Technical Data and Specifications	3-77
Type CH and BR Cross-Reference	3-80
Classified Circuit Breakers	3-82
OEM Loadcenter Interiors	3-85



Residential Loadcenters and Breaker Family

Don't Give Up!
 If you don't find the product you want in this catalog, try the Flex Center at 1-800-330-6479.

Product Description

Product Description

Loadcenters are enclosures specifically designed to house the branch circuit breakers and wiring required to distribute power to individual circuits. They contain either a main breaker when used at the service entrance point or a main lug when used as a sub-panel to add circuits to existing service. The main breaker protects the main entire panel and can be used as a service disconnect. The branch breakers protect the wires leading to individual electrical loads such as fixtures and outlets.

3



*Single-Phase Main Circuit Breaker —
Top or Bottom Feed — NEMA® 1 Enclosure*



Separately Packaged Covers



*Three-Phase Main Circuit Breaker —
NEMA 3R Enclosure*

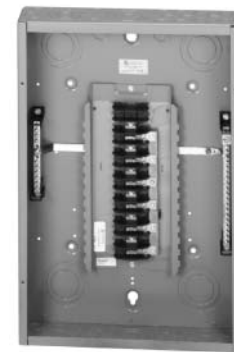

MLO Panel



Cutler-Hammer® Type CH Breaker Family

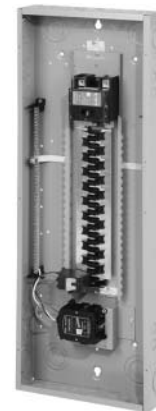

Surge Panel



Cutler-Hammer Type CH Convertible Family

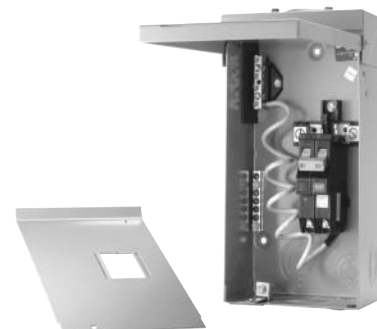

Spa Panel or Ground Fault Protection Kit

Application Description

Loadcenter Construction

Cutler-Hammer Type CH loadcenters by Eaton Corporation feature silver flash plated copper bus in all interiors. Fingers are rated 200 amperes throughout the CH line. Therefore, the sum of the handle ratings connected to any one stab is limited to 200 amperes maximum. NEMA 1 boxes are manufactured from cold rolled 16 gauge sheet steel. Raintight boxes are manufactured from galvanized steel. All boxes and trims are finished using an electrostatic powder coat, baked urethane paint process.

Neutrals

Cutler-Hammer Type CH loadcenters feature three types of neutrals:

Factory-Bonded Split Neutral

Single-phase main circuit breaker panels are supplied with a factory-bonded twin neutral. When used as a sub-panel, the bonding strap should be removed, and the bonding screw should be reinstalled. The bonded side is now the ground, and the un-bonded side is the neutral. When used as a service entrance panel, the unused neutral holes on either side may be used for terminating ground wires.

Insulated Split Neutral

Most single-phase main lug panels (12 circuits and greater) are supplied with a twin neutral with an insulated cross strap. These panels are shipped in an un-bonded state. For service entrance applications, the neutral must be bonded utilizing the bonding strap supplied with the panel. For sub-feed applications, the panel may be installed as is. Separate ground bars are provided on these panels.

Insulated/Bondable Single Neutral

When a panel is supplied with a single neutral, it arrives from the factory in an "unbonded" state. All that is required to bond the neutral in a service entrance application is to loosen the bonding screw and the neutral screw directly beside it, insert the bonding strap into the neutral bar, and re-tighten both connections. The single neutral can be moved by the contractor to the other side of the panel, if desired. In a service entrance application, where the neutral is bonded, unused neutral connections may be used for the termination of equipment grounds.

Grounds

In service entrance applications where the neutral is bonded, unused neutral holes may be used for terminating ground conductors. In sub-feed panels, the neutral must be isolated (non-bonded), and ground wires must be terminated on a separate ground bar.

The Factory Bonded Split Neutral panels have sufficient terminations for both ground and neutral conductors. The Insulated Split Neutral panels are supplied with a separate factory-installed ground bar. Insulated/Bondable Single Neutral panels are supplied without a ground bar (unless otherwise noted), and ground bar kits if needed must be purchased separately.

Surge Protectors

The CHSURGE Surge Protector has indicating lights that indicate when the units should be replaced. The CHSA01 and CHSA03 Surge Protectors internally short, causing the circuit breaker feeding the surge protector to trip. All but the CHSURGE Surge Protector should be wired to the load side of 15 or 20 ampere feeder circuit breakers mounted adjacent to the main incoming device.

The CHSPULTRA Cutler-Hammer Home Surge Protector is an externally mounted TVSS unit that provides industrial level surge protection in a residential design.

The CHSPULTRA is also available factory installed in the loadcenter and carries a lifetime warranty.

Standards and Certifications

UL® Listings

All Cutler-Hammer Type CH loadcenters by are listed under UL File E8741.

Neutral and Ground Terminals

The standard terminals on grounds and neutrals are rated to accept (3) — #14 – #10 Cu/Al or (1) — #14 – 4 wires. For larger cables, add-on neutral lugs may be ordered from the accessories on **Pages 3-23** and **3-24**.

Note: NEC® allows only one current carrying conductor per hole on neutrals unless otherwise noted.

Bottom-Fed Loadcenters

When the power cable is brought into the loadcenter from below the panel; then the main lug panels, and single-phase, 225 amperes and below, loadcenters can be rotated 180 degrees to allow straight-in wiring of power cables to the main terminals. Because the CSR main circuit breaker handle operates horizontally, the orientation of the main circuit breaker handle is consistent with the requirements of NEC Article 240-81.

Gutter Splicing

Loadcenters are not UL listed as wiring troughs. Therefore, gutter splicing of riser cables to tap off to the main device is not permitted. Refer to NEC Article 373-8.

Fire Rating

Due to the numerous openings in both loadcenter boxes and trims, they should not be mounted in firewalls. There is no approval method for sealing the enclosures for this application.

Date Code

The date of manufacture of each loadcenter is printed on the outside of the carton as well as inside the loadcenter. On the carton, the date code is printed on the end carton label. In the loadcenter, the date code is located on the small white label located on the right side wall (with the main device on top).

The date code is in the following format: F ### &. The "F" is the numeric code for the Lincoln, IL plant, and the three numbers are the year and week of manufacture e.g., 023. The "&" sign at the end signifies the decade of the 2000s. Therefore, the date code F023& would indicate that the product was manufactured in the 23rd week of 2000. The 1980s are represented by a "+" sign and the 1990s are represented by a "=" at the end of the code.

Standards and Certifications**Plug-on Type CH Breakers****Description**

Quick-make, quick-break switch mechanism combined with inverse time element tripping operation and trip-free handle design. Type CH circuit breakers trip to the OFF position eliminating nuisance callbacks. The thermal-magnetic trip curve avoids nuisance tripping on mild overloads while reacting almost instantaneously to severe short circuit conditions. Multipole breakers have internal common trip connection to operate all poles simultaneously. Handles are marked with ON-OFF indication and ampere rating of the breaker. Type CH breakers meet UL Standard 489, NEMA standards, and Federal Spec Classification W-C 375 b/Gen. They are UL listed under File Number E11713, E8741, E3624 and E51287; and CSA certified file number LR87196, except Type CHT breakers.

Type CH Circuit Breaker Ratings

Single- and double-pole CH breakers rated 15 and 20 amperes have low instantaneous magnetic trip levels. The 15 and 20 ampere breakers with "HM" suffix have high magnetic trip settings recommended for circuits with inherently high inrush currents. All Type CH breakers are marked for heating, air conditioning and refrigeration (HACR) equipment application. Single-pole 15 – 20 ampere breakers are also suitable for switching duty (SWD). Shunt trip coils operate on 120 Vac and require one additional pole space per breaker.

Features, Benefits and Functions

Extra 1.5-Inch (38.1 mm) Knockout for Bundling

Provides for easier installation, less installation time.

Top or Bottom Feed

- Straight-in wiring saves labor and material.
- Only one panel for either application — no modifications necessary.

Commercial Grade Main Breaker

- 35 kAIC series rated main breaker in 150 and 200 ampere loadcenters.
- 42 and 100 kAIC series ratings available.

Drywall Marking on Enclosure

Indicates proper mounting depth for flush applications.

One-Piece Silver Flash Plated Copper Bus

Provides superior conductivity throughout the entire product line.

Steel Backpan

- Provides positive, reliable breaker mounting.
- One-piece designed for stability.

Convertible Styles Available

- Uses field installable main breaker or main lug kits.
- Flexible inventory — same breaker is used in loadcenter and circuit breaker enclosures.



“Tangential” Center Knockout
For easier installation

Single Keyhole Mounting
Just one keyhole at top and bottom for easier mounting and leveling.

Unique Sandalwood Finish
Immediately recognizable, esthetically appealing, scratch resistant powder coating.

Separately Packaged Covers

- Full line of “true” surface and combination covers.
- Built-in flush leveling feature.
- Choice of circuit identification by breaker labels or circuit directory.

Neutral Design (For styles as indicated)

- Bonding strap is easily removable for sub-panel applications providing a ground and neutral.
- Factory bonded for service entrance applications providing a split neutral.
- Ample additional 2/0 lugs provided; no kits necessary.
- 200% size neutral.

Improved Endwall Knockouts
Larger KOs are balanced to enhance installed appearance and to ease use of existing wiring.

Type CH Loadcenter

Product Specifications

Product Specifications

General

3

- A. The Contractor shall furnish and install loadcenters incorporating circuit breakers of the number, rating and type as specified herein and as shown on the contract drawings.
- B. The loadcenter and all components shall be designed, manufactured and tested in accordance with the latest applicable standards of UL and NEMA including:
 1. UL 67 — Standards for Panelboards
 2. UL 50 — Standards for Cabinets and Boxes
 3. UL 489 — Standards for Molded Case Circuit Breakers
 4. Federal Spec Classification W-C 375
 5. UL 1699 — All Fault Interrupting

Qualifications

- A. The manufacturer of the loadcenter shall be the manufacturer of the circuit breaker within the load center. All breakers shall be full size.
- B. For the equipment specified herein, the manufacturer shall be ISO® 9000 certified.
- C. The manufacturer of this equipment shall have produced similar electrical equipment for a minimum period of seven (7) years.

Manufacturers

- A. Eaton

Ratings

- A. Loadcenters shall be rated for 240 Vac and shall have short circuit ratings as shown on the drawings or as herein scheduled, but not less than 10,000 amperes rms symmetrical.
- B. Breakers shall be full size and a minimum of 125 ampere frame. Breakers 10 through 125 ampere trip size shall take up the same pole spacing.

- C. Loadcenters shall be labeled with a UL short circuit rating. When series ratings are applied with integral or remote devices, a label shall be provided. Series ratings shall cover all trip ratings of installed frames. It shall state the conditions of the UL series ratings including:
 1. Size and type of upstream device.
 2. Branch devices that can be used.
 3. UL series short circuit rating.

Construction

- A. All interiors, with the exception of the branch circuit breakers shall be completely factory assembled with main breakers, main lugs or no main device.
- B. Interiors shall be so designed that circuit breakers can be replaced without disturbing adjacent units and without removing the main bus connectors and shall be so designed that circuits may be changed without machining, drilling or tapping.
- C. Physical means must be provided to prevent the installation of more overcurrent devices than that number for which the enclosure was designed. Full size breakers are required.

Bus

- A. Bus bars for the main and cross connectors shall be of silver flash plated copper construction in accordance with UL standards. Bussing shall be braced to 65 kAIC.
- B. Neutral bussing shall have a suitable lug for each outgoing feeder requiring a neutral connection of same ampacity as branch.

Wiring/Termination

- A. All wire connectors and terminals shall be of the anti-turn solderless type and suitable for copper or aluminum wire of the sizes indicated. All connectors shall meet the "Requirements for Wire Connectors and Soldering Lugs" UL 486B.
- B. All loadcenters where marked shall be suitable for use with 60/75°C rated wire.

Circuit Breakers

- A. Circuit breakers shall be molded case type, 3/4-inch (19.1 mm) wide per pole. Multipole circuit breakers shall be of a stack pole design to provide electrical phase isolation and have an internal common trip.
- B. Each pole of the circuit breaker will have inverse time delay overload and instantaneous short circuit protection by means of both thermal and magnetic sensors. Circuit breakers shall be quick-make/quick-break.
- C. The circuit breaker calibration shall not be affected by environmental changes in relative humidity. Breakers shall be calibrated after assembly.
- D. All circuit breakers shall be operated by a toggle-type handle and multipole circuit breakers shall have an internal common trip mechanism. The circuit breakers shall incorporate trip mechanisms that are mechanically trip-free from the handle. The handle position shall provide good visual trip indication.
- E. Contacts shall be of non-welding silver alloy.
- F. All branch breaker handles shall be of a different color than the case of the breaker.
- G. All terminals shall be listed for use with copper or aluminum conductors. Terminals shall be of the box lug design. The terminals shall meet UL 486B requirements and shall be suitable for use with either 60° or 75°C wire.
- H. Breakers shall be SWD rated and/or HACR rated as required.
- I. Arc Fault Interrupting circuit breakers, (AFC), shall be provided on all 15 and 20 ampere single-phase 120/240 Vac circuits except those indicated as remote controlled breakers. AFI breakers shall be "Classified for mitigating the effects of arcing faults," or conforming to UL Standard 1699 and as defined by per article 210-12 Section A of the 1999 NEC Code.

Enclosures

- A. Loadcenters shall have NEMA 1 general purpose or NEMA 3R rain-proof enclosures as indicated on the drawings and shall be surface or flush mounted except where noted.
- B. For indoor applications, enclosures shall be rated NEMA 1. Enclosures shall be manufactured from cold-rolled code-gauge sheet steel having multiple knockouts and painted per paint specification. For outdoor applications, enclosures shall be rated NEMA 3R. Enclosures shall be manufactured from galvanized steel which shall be painted per the painted as specified. Enclosures shall be of sufficient size to meet or exceed NEC wire bending space.
- C. The cover shall have an easy adjustment feature for flush applications.
- D. Boxes shall be factory assembled into a single rigid structure.
- E. Provide circuit breaker marking labels and directories.

Finish

- A. Boxes and trims shall be finished with a high scratch-resistant aesthetically pleasing finish. The finish shall be polyurethane coating electrostatically applied to a thickness of 1.8 to 2 mils.
- B. All loadcenters shall be provided with provisions for accepting a paintable or wall paperable decorator accessory cover. Where loadcenters are installed in living areas, provide manufacturer designed and tested decorator cover kits.

Warranty

The minimum warranty for Residential loadcenters, breakers and surge protection devices shall be as follows:

- Lifetime loadcenter warranty
- Lifetime warranty on all Arc Fault Circuit Interrupting Circuit Breakers
- Lifetime Warranty on CHSPULTRA including \$5000 connected load warranty
- Lifetime warranty on all thermal magnetic and GFCI branch circuit breakers
- 1-year warranty on plug-in surge protection device (CHSURGE)

Product Selection

Product Selection

Table 3-1. CH Loadcenter Selection Chart

Service	<ul style="list-style-type: none"> Single-phase, three-wire, 120/240 Vac. Three-phase, three-wire, 240V corner grounded delta (see Accessories Page 3-24). 	<ul style="list-style-type: none"> Three-phase, four-wire, 208Y/120 Vac. Three-phase, three-wire, 240 Vac delta.
Short Circuit Current Rating	<ul style="list-style-type: none"> 10,000 AIC: All single- and three-phase loadcenters 40 through 400 amperes, 2 to 42 circuits except when series ratings are applied. 35,000 AIC: All convertible and factory installed main breakers single-phase loadcenters rated 150 through 225 amperes using Type CSH main breakers. 42,000 and 100,000 are available on some styles: single-phase and three-phase. 	
Main Breaker/Main Lug Loadcenters	Single-Phase <ul style="list-style-type: none"> Main Breaker: 100, 125, 150, 200, 225, 400 amperes. Main Lugs: 40, 70, 125, 150, 200, 225, 400 amperes. 	Three-Phase <ul style="list-style-type: none"> Main Breaker: 150, 200, 225, 300, 400 amperes. Main Lugs: 125, 150, 200, 225, 400 amperes.
Convertible Loadcenters	<ul style="list-style-type: none"> Main Breaker or Main Lugs: single-phase up to 225 amperes 	
Branch Breakers	<ul style="list-style-type: none"> Type CH: 10 to 150 amperes. One-, two-, and three-pole. Selected amperages available in shunt trip, HACR and switching duty. Ground Fault Breakers: 15 to 60 amperes. Type CH-HID: 15 to 30 amperes. One-, two- and three-poles. PMPCCI Breakers. CH-HM High Magnetic. CH-M50 High Ambient. 	<ul style="list-style-type: none"> Type CH-AFCI arc fault circuit interrupter. Type CHP: 10 to 125 amperes. One-, two- and three-pole. Three-position commercial trip. Selected amperages available in HACR switching duty. Type CHP-HID: 15 to 30 amperes. One-, two- and three-pole. Type CHP-GFCI: 15 to 30 amperes. One-pole ground fault breakers.
Enclosures	<ul style="list-style-type: none"> NEMA Type 1 indoor. NEMA Type 3R outdoor. 	<ul style="list-style-type: none"> Meets or exceeds UL requirements for indoor or outdoor applications.
Loadcenter and Breaker Accessories	<ul style="list-style-type: none"> Branch Circuit Breaker: Auxiliary components Hold down kits Handle ties Lockoffs Lockdogs Complete Line of Ground Bar Kits 5, 10, 14 and 21 circuits, some with additional #2/0 lugs. Each terminal will accommodate: (3) #14 – #10 Cu/Al or (1) #14 – #4 Cu/Al. Sub-feed Lugs 125, 150 amperes — two- and three-pole. Shunt trips. 	<ul style="list-style-type: none"> Surge Protection: Single-phase whole home surge protector Single-phase plug-on surge protector Single-phase bottle type surge protector Three-phase bottle type surge protector Universal rainproof conduit hubs Group One: 3/4, 1, 1-1/4, 1-1/2, 2 inches (19.1, 25.4, 31.8, 38.1, 50.8 mm). Group Two: 2, 2-1/2, 3 inches (50.8, 63.5, 76.2 mm). Adapter plate.
Bussing	<ul style="list-style-type: none"> Silver Flash Plated Copper Bus is a standard feature. 	

Table 3-2. Loadcenters 100 – 225 Amperes and 12 – 42 Circuits Catalog Numbering System

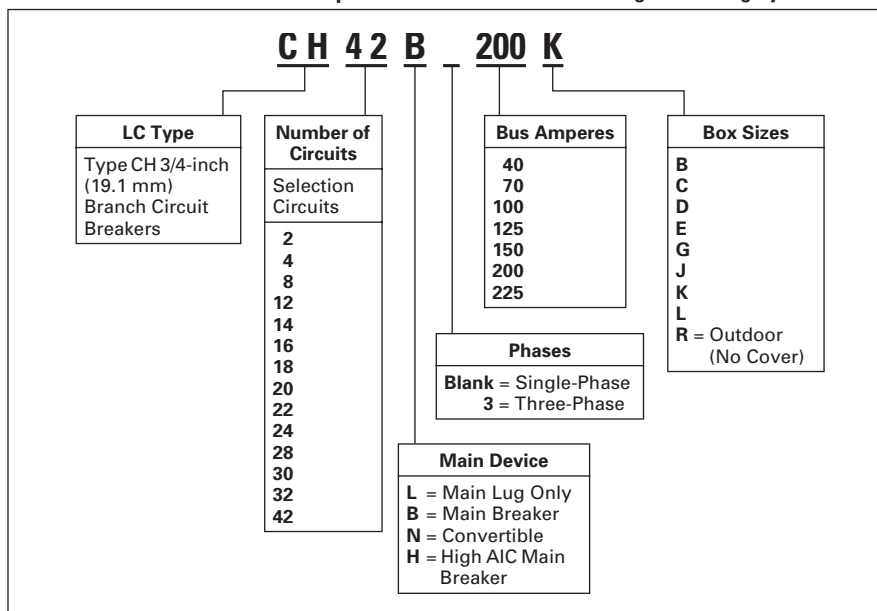
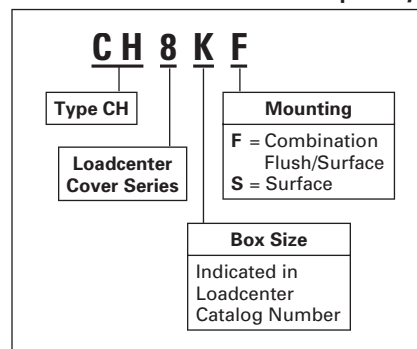

Table 3-3. Indoor Covers Ordered Separately



Note: All combinations are not valid, refer to the catalog section.

Product Selection

Single-Phase — Main Circuit Breaker Loadcenters
10,000/35,000 Amperes Interrupting Capacity

Table 3-4. Single-Phase 3-Wire — 120/240 Vac — Factory Bonded Split Neutral (Unless Otherwise Noted)

Main Breaker Type	Main Ampere Rating	Maximum Number 3/4-Inch (19.1 mm) Poles	Enclosure Type	Box Size	Wire Size Range Cu/Al 60°C or 75°C for Main Breaker	Loadcenter ①② Catalog Number	Price U.S. \$	Loadcenter Cover Catalog Number		Price U.S. \$	
								Combination ③	Surface		
CH 10 kAIC	100	14	Indoor	B	#6 – 1/0	CH14B100B ④⑤		CH8BF	CH8BS		
		14	Outdoor	B		CH14B100R ⑥⑦		—	—		
		18	Indoor	C		CH18B100C ④⑤		CH8CF	CH8CS		
		18	Outdoor	C		CH18B100R ⑥⑦		—	—		
		22	Indoor	C		CH22B100C ④⑤		CH8CF	CH8CS		
		22	Outdoor	C		CH22B100R ⑥⑦		—	—		
	125	30	Indoor	D	#6 – 1/0	CH30B100D ④⑤		CH8DF	CH8DS		
		30	Outdoor	D		CH30B100R ⑥⑦		—	—		
		22	Indoor	C		CH22B125C ④⑤		CH8CF	CH8CS		
		22	Outdoor	C		CH22B125R ⑥⑦		—	—		
		30	Indoor	D		CH30B125D ④⑤		CH8DF	CH8DS		
		30	Outdoor	D		CH30B125R ⑥⑦		—	—		
CSH 35 kAIC ⑧	150	8	Outdoor	E	#2 – 300 kcmil	CH8B150RF ⑥⑧⑨		—	—		
		24	Indoor	E		CH24B150E ④⑤		CH8EF	CH8ES		
		24	Outdoor	E		CH24B150R ⑥⑦		—	—		
		32	Indoor	J		CH32B150J ④⑤		CH8JF	CH8JS		
		32	Outdoor	J		CH32B150R ⑥⑦		—	—		
		200	8	Outdoor		E		#2 – 300 kcmil	CH8B200RF ⑥⑧⑨		
	24		Indoor	E	CH24B200E ④⑤	CH8EF	CH8ES				
	24		Outdoor	E	CH24B200R ⑥⑦	—	—				
	32		Indoor	J	CH32B200J ④⑤	CH8JF	CH8JS				
	32		Outdoor	J	CH32B200R ⑥⑦	—	—				
	42		Indoor	K	CH42B200K ④⑤	CH8KF	CH8KS				
	225	42	Outdoor	K	#2 – 300 kcmil	CH42B200R ⑥⑦		—	—		
		32	Indoor	J		CH32B225J ④⑤		CH8JF	CH8JS		
		32	Outdoor	J		CH32B225R ⑥⑦		—	—		
		42	Indoor	K		CH42B225K ④⑤		CH8KF	CH8KS		
		42	Outdoor	K		CH42B225R ⑥⑦		—	—		
		DK 10 kAIC	300	42		Indoor		PM	(2) 3/0 – 250 kcmil		CH42PM300
	400		42	Indoor	PM	(2) 3/0 – 250 kcmil	CH42PM400		CH7PMF ⑩	CH7PMS	

- ① All main circuit breaker loadcenters are listed for use as service entrance equipment.
- ② Ground bar kits priced separately. See **Page 3-24**.
- ③ Combination style covers may be used in surface or flush applications.
- ④ Loadcenters are factory bonded for service entrance applications. Remove bonding strap for separate neutral and ground bars for sub-feed applications.
- ⑤ Can be top or bottom fed by rotating the enclosure and trim 180 degrees.
- ⑥ Loadcenter contains single insulated/bondable neutral.
- ⑦ Rainproof panels are furnished with hub closure plates. For rainproof hubs, refer to **Page 3-24**.
- ⑧ 35,000 AIC series combination rating is obtained when Types CH, CHT and CHP branch breakers are used with CSH main.
- ⑨ Panel includes #4 – 300 kcmil feed-through lugs.
- ⑩ This cover is for flush applications only (not combination).

3

Product Selection

Single-Phase — High Interrupting Rated Main Circuit Breaker Loadcenters
42,000/100,000 Amperes Interrupting Capacity

Table 3-5. Single-Phase 3-Wire — 120/240 Vac — Factory Bonded Split Neutral (Unless Otherwise Noted)

Main Breaker Type	Main Ampere Rating	Maximum Number 3/4-Inch (19.1 mm) Poles	Enclosure Type	Box Size	Wire Size Range Cu/Al 60°C or 75°C for Main Breaker	Loadcenter ① Catalog Number	Price U.S. \$	Loadcenter Cover Catalog Number		Price U.S. \$
								Combination ②	Surface	
CHB4 42 kAIC ③	100	20	Indoor	C	#6 – 1/0	CH20H100C ④⑤ CH20H100R ⑥⑦ CH28H100D ④⑤ CH28H100R ⑥⑦		CH8CF	CH8CS	
		20	Outdoor	C				—	—	
		28	Indoor	D				CH8DF	CH8DS	
		28	Outdoor	D				—	—	
CHH 100 kAIC ⑧	150	32	Indoor	L	#2/0 – 300 kcmil	CH32H150L ④ CH32H150R ⑥⑦		CH8LF	CH8LS	
		32	Outdoor	L				—	—	
	200	32	Indoor	L	#2/0 – 300 kcmil	CH32H200L ④ CH32H200R ⑥⑦ CH42H200L ④ CH42H200R ⑥⑦		CH8LF	CH8LS	
		32	Outdoor	L				—	—	
		42	Indoor	L				CH8LF	CH8LS	
		42	Outdoor	L				—	—	
	225	42	Indoor	L	#2/0 – 300 kcmil	CH42H225L ④ CH42H225R ⑥⑦		CH8LF	CH8LS	
		42	Outdoor	L				—	—	

- ① All main circuit breaker loadcenters are listed for use as service entrance equipment.
- ② Combination style covers may be used in surface or flush applications.
- ③ Series rated for 42,000 AIC with all Types CH, CHT and CHP breakers.
- ④ Loadcenters are factory bonded for service entrance applications. Remove bonding strap for separate neutral and ground bars for sub-feed applications.
- ⑤ Loadcenter can be top or bottom fed by rotating the enclosure and trim 180 degrees.
- ⑥ Rainproof panels are furnished with hub closure plates. For rainproof hubs, refer to **Page 3-24**.
- ⑦ Loadcenter contains single insulated/bondable neutral.
- ⑧ Series rated for 100,000 AIC with all Types CH, CHT and CHP breakers.

Box Sizes **Pages 3-38 and 3-39**
 Discount Symbol **22CD**

Product Selection

2 Circuits 40 and 70 Amperes

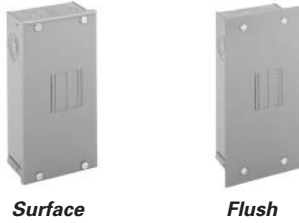

Surface

Flush

4 and 8 Circuits 125 Amperes



Surface (No Door)

Flush (No Door)

2 Circuits 125 Amperes

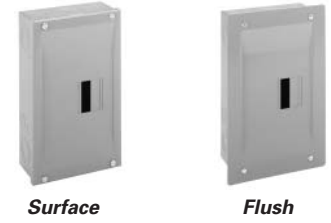

Surface

Flush



Outdoor



Outdoor



Outdoor

Single-Phase — Main Lug Loadcenters

Table 3-6. Single-Phase 3-Wire — 120/240 Vac — Insulated/Bondable Neutral

Main Ampere Rating	Maximum Number 3/4-Inch (19.1 mm)		Enclosure Type	Type of Trim (Included)	Box Size	Wire Size Range Cu/Al 60°C or 75°C for Main Lugs	Loadcenter Catalog Number	Price U.S. \$
	Space	Poles						
40	2	4 ①	Indoor	Surface (No Door)	5	#14 – 6	CH2L40SP ②③ CH2L40RP ②③④ CH2L40FP ②③	
	2	4 ①	Outdoor	—	5R			
	2	4 ①	Indoor	Flush (No Door)	5			
70	2	4 ①	Indoor	Surface (No Door)	5	#14 – 2	CH2L70SP ②③ CH2L70RP ②③④ CH2L70FP ②③	
	2	4 ①	Outdoor	—	5R			
	2	4 ①	Indoor	Flush (No Door)	5			
125	2	4 ①	Indoor	Surface (No Door)	6	#14 – 1/0	CH2L125SP ②③ CH2L125RP ②③④ CH2L125RSE2P ④⑤⑥ CH2L125FP ②③	
	2	4 ①	Outdoor	—	6R			
	2	2	Outdoor	—	—			
	2	4 ①	Indoor	Flush (No Door)	6			
	4	8 ①	Indoor	Surface (No Door)	7	#14 – 1/0	CH4L125SP ②⑦ CH4L125RP ②④⑦ CH4L125FP ②⑦	
	4	8 ①	Outdoor	—	7R			
	4	8 ①	Indoor	Flush (No Door)	7			
	8	16 ①	Indoor	Surface (No Door)	7	#6 – 1/0	CH8L125SP ②⑧ CH8L125RP ②⑥⑦ CH8L125FP ②⑧	
	8	16 ①	Outdoor	—	7R			
	8	16 ①	Indoor	Flush (No Door)	7			

- ① Requires the use of Type CHNT breakers.
- ② Ground bar kits priced separately, see **Page 3-24**.
 – For 2/4 circuit loadcenters use Type GBK5 or GBK520 ground bar
 – For 4/8 and 8/16 circuit loadcenters use Type GBK10 ground bar
 – Ground bars mount to the left side wall of the enclosure for the 4/8 and 8/16 circuit loadcenters.
- ③ Suitable for use as service equipment when not more than two service disconnecting mains are provided or when not used as a lighting and appliance panelboard (see Article 408.34 of the NEC).
- ④ Rainproof panels are furnished with hub closure plates. For rainproof hubs, refer to **Page 3-24**.
- ⑤ For use as service entrance applications only.
- ⑥ Neutral/ground holes (6) #14 – 6 and (3) #14 – 2/0 AWG Cu/Al.
- ⑦ Suitable for use as service equipment when not more than two service disconnecting mains are provided or when not more than six service disconnecting mains are provided and when not used as a lighting and appliance panelboard (see Article 408.34 of the NEC).
- ⑧ Suitable for use as service equipment when a main breaker is used or when not more than six service disconnecting mains are provided and when not used as a lighting and appliance panelboard (see Article 408.34 of the NEC).

Box Sizes **Pages 3-38 and 3-39**
 Discount Symbol **22CD**

Product Selection

Single-Phase — Main Lug Loadcenters

Table 3-7. Single-Phase 3-Wire — 120/240 Vac — Twin Neutral — Factory-Installed Ground Bar

Main Ampere Rating	Maximum Number 3/4-Inch (19.1 mm) Poles	Enclosure Type	Box Size	Wire Size Range Cu/Al 60°C or 75°C for Main Lugs	Loadcenter Catalog Number	Price U.S. \$	Loadcenter Cover Catalog Number		Price U.S. \$
							Combination	Surface	
125	12	Indoor	B	#6 – 2/0	CH12L125B ①		CH8BF	CH8BS	
	12	Outdoor	B		CH12L125R ①②		—	—	
	16	Indoor	B		CH16L125B ①		CH8BF	CH8BS	
	16	Outdoor	B		CH16L125R ①②		—	—	
	20	Indoor	C		CH20L125C ①		CH8CF	CH8CS	
	20	Outdoor	C		CH20L125R ①②		—	—	
	24	Indoor	C		CH24L125C ①		CH8CF	CH8CS	
24	Outdoor	C	CH24L125R ①②	—	—				
150	24	Indoor	D	#4 – 300 kcmil	CH24L150D ①		CH8DF	CH8DS	
	24	Outdoor	D		CH24L150R ②③		—	—	
	32	Indoor	D		CH32L150D ①		CH8DF	CH8DS	
	32	Outdoor	D		CH32L150R ②③		—	—	
200	12	Indoor	D	#4 – 300 kcmil	CH12L200D ①		CH8DF	CH8DS	
	12	Outdoor	D		CH12L200R ②③		—	—	
	16	Indoor	D		CH16L200D ①		CH8DF	CH8DS	
	16	Outdoor	D		CH16L200R ②③		—	—	
225	24	Indoor	D	#4 – 300 kcmil	CH24L225D ①		CH8DF	CH8DS	
	24	Outdoor	D		CH24L225R ②③		—	—	
	32	Indoor	D		CH32L225D ①		CH8DF	CH8DS	
	32	Outdoor	D		CH32L225R ②③		—	—	
	42	Indoor	G		CH42L225G ③		CH8GF	CH8GS	
	42	Outdoor	G		CH42L225R ②③		—	—	
400	42	Indoor	P	(2) 1/0 – 300 kcmil (1) 750 kcmil	CH42PL400 ④		CH7PF ⑤	CH7PS	

- ① Suitable for use as service equipment when not more than six disconnecting means are provided and when not used as a lighting and appliance panelboard (see Article 408.34 of the NEC).
- ② Rainproof panels are furnished with hub closure plates. For rainproof hubs, refer to **Page 3-24**.
- ③ Suitable for use as service equipment when a circuit breaker is used as a main breaker. The main breaker is backfed and requires hold-down bracket kit catalog number **CH125RB**.
- ④ Suitable for use as service equipment when a circuit breaker is used as a main breaker. The main breaker is backfed and must be a Type CHB. **The breaker cannot be a Type CH.**
- ⑤ This cover is for flush application only (not combination).

Box Sizes **Pages 3-38 and 3-39**
 Discount Symbol **22CD**

3-Phase — Main Circuit Breaker Loadcenters
10,000 Amperes Interrupting Capacity

Table 3-8. 3-Phase 4-Wire — 208Y/120 Vac or 240 Vac Insulated/Bondable Neutral

Main Breaker Type	Main Ampere Rating	Maximum Number 3/4-Inch (19.1 mm) Poles	Enclosure Type	Box Size	Wire Size Range Cu/Al 60°C or 75°C for Main Breaker	Loadcenter ^{①②} Catalog Number	Price U.S. \$	Loadcenter Cover Catalog Number		Price U.S. \$
								Combination	Surface	
CC 10 kAIC	150	30 30	Indoor	L	#1 – 4/0	CH30B3150L		CH8LF	CH8LS	
			Outdoor	L		CH30B3150R ^③		—	—	
	200	30 30 42 42	Indoor Outdoor Indoor Outdoor	L	#2/0 – 300 kcmil	CH30B3200L		CH8LF	CH8LS	
				L		CH30B3200R ^③		—	—	
				L		CH42B3200L		CH8LF	CH8LS	
				L		CH42B3200R ^③		—	—	
	225	30 30 42 42	Indoor Outdoor Indoor Outdoor	L		CH30B3225L		CH8LF	CH8LS	
				L		CH30B3225R ^③		—	—	
				L		CH42B3225L		CH8LF	CH8LS	
				L		CH42B3225R ^③		—	—	
	400	42	Indoor	PM	(2) 3/0 – 350 kcmil	CH424PM400		CH7PMF ^④	CH7PMS	

- ① All main circuit breaker loadcenters are listed for use as service entrance equipment.
- ② Ground bar kits priced separately. See **Page 3-24**.
- ③ Rainproof loadcenters are furnished with hub closure plates. For rainproof hubs, refer to **Page 3-24**.
- ④ This cover for flush application only (not combination).

Product Selection

3-Phase — Main Lug Loadcenters

Table 3-9. 3-Phase 4-Wire — 208Y/120 Vac or 240 Vac — Insulated/Bondable Neutral

Main Ampere Rating	Maximum Number 3/4-Inch (19.1 mm)		Enclosure Type	Type of Trim Included	Box Size	Wire Size Range Cu/Al 60°C or 75°C for Main Lugs	Loadcenter Catalog Number	Price U.S. \$
	Spaces	Poles						
125	6	12 ①	Indoor	Surface No Door	7	#14 – 1/0	CH6L3125SP ②③ CH6L3125RP ②③④ CH6L3125FP ②③	
	6	12 ①	Outdoor	—	7R			
	6	12 ①	Indoor	Flush No Door	7			

- ① Requires the use of CHNT breakers.
- ② Suitable for use as service equipment when not more than two service disconnecting means are provided or when not more than six service disconnecting means are provided and when not used as a lighting and appliance panelboard (see Article 408.34 of the NEC).
- ③ Ground bar kits priced separately, see **Page 3-24**.
– Use GBK10 ground bar
– Ground bars mount to the left side wall of the enclosure.
- ④ Rainproof panels are furnished with hub closure plates. For rainproof hubs, refer to **Page 3-24**.

Table 3-10. 3-Phase 4-Wire — 208Y/120 Vac or 240 Vac — Insulated/Bondable Neutral

Main Ampere Rating	Maximum Number 3/4-Inch (19.1 mm) Poles	Enclosure Type	Box Size	Wire Size Range Cu/Al 60°C or 75°C for Main Lugs	Loadcenter Catalog Number	Price U.S. \$	Loadcenter Cover Catalog Number		Price U.S. \$
							Combination	Surface	
125	12	Indoor	B	#6 – 2/0	CH12L3125B ⑤⑥		CH8BF	CH8BS	
	12		B		CH12L3125R ⑤⑥⑦		—	—	
	18	Indoor	C		CH18L3125C ⑤⑥		CH8CF	CH8CS	
	18	Outdoor	C		CH18L3125R ⑤⑥⑧		—	—	
	24	Indoor	C		CH24L3125C ⑤⑥		CH8CF	CH8CS	
	24	Outdoor	C		CH24L3125R ⑤⑥⑧		—	—	
150	30	Indoor	D	#4 – 300 kcmil	CH30L3150D ⑤⑥		CH8DF	CH8DS	
	30		Outdoor		D		CH30L3150R ⑤⑦⑧	—	
225	24	Indoor	D	#4 – 300 kcmil	CH24L3225D ⑤⑥		CH8DF	CH8DS	
	24		Outdoor		D		CH24L3225R ⑤⑦⑧	—	
	30	Indoor	D		CH30L3225D ⑤⑥		CH8DF	CH8DS	
	30	Outdoor	D		CH30L3225R ⑤⑦⑧		—	—	
	42	Indoor	G		CH42L3225G ⑥⑧		CH8GF	CH8GS	
	42	Outdoor	G		CH42L3225R ⑦⑧⑨		—	—	
400	42	Indoor	P	(2) 1/0 – 300 kcmil (1) 750 kcmil	CH424PL400 ⑩⑪		CH7PF ⑫	CH7PS	

- ⑤ Ground bar Type GBK14 is installed.
- ⑥ Suitable for use as service equipment when a circuit breaker is used as a main breaker. The main breaker is backfed and requires hold-down bracket kit catalog number Type **CH125RB**. Suitable for use as service equipment when not more than six service disconnecting means are provided and when not used as a lighting and appliance panelboard (see Article 408.34 of the NEC).
- ⑦ Rainproof panels are furnished with hub closure plates. For rainproof hubs, refer to **Page 3-24**.
- ⑧ Suitable for use as service equipment when a circuit breaker is used as a main breaker. The main breaker is backfed and requires hold-down kit catalog number Type **CH125RB**.
- ⑨ Ground bar Type GBK21 is installed.
- ⑩ Suitable for use as service equipment when a circuit breaker is used as a main breaker. The main breaker is backfed and must be a Type CHB. **The breaker cannot be a Type CH.**
- ⑪ Ground bar kit priced separately, see **Page 3-24**.
- ⑫ This cover is for flush application only (not combination).

3-Phase — High Interrupting Rated Main Circuit Breaker Loadcenters — 100,000 Amperes Interrupting Capacity

Table 3-11. 3-Phase 4-Wire — 208Y/120 Vac or 240 Vac Insulated/Bondable Neutral

Main Breaker Type	Main Ampere Rating	Maximum Number 3/4-Inch (19.1 mm) Poles	Enclosure Type	Box Size	Wire Size Range Cu/Al 60°C or 75°C for Main Breaker	Loadcenter ⑬⑭ Catalog Number	Loadcenter Cover Catalog Number	
							Combination	Surface
CHH 100 kAIC ⑮	200	30	Indoor	L	#2/0 – 300 kcmil	CH30H3200L	CH8LF	CH8LS
			Outdoor	L		CH30H3200R ⑯	—	—
		Indoor	L	CH42H3200L		CH8LF	CH8LS	
		Outdoor	L	CH42H3200R ⑯		—	—	
	225	42	Indoor	L	#2/0 – 300 kcmil	CH42H3225L	CH8LF	CH8LS
			Outdoor	L		CH42H3225R ⑯	—	—

- ⑬ All main circuit breaker loadcenters are listed for use as service entrance equipment.
- ⑭ Ground bar kits priced separately.
- ⑮ 100,000 AIC series combination rating is obtained when Types CH and CHP branch breakers are used with CHH main.
- ⑯ Rainproof loadcenters are furnished with hub closure plates.

Box Sizes **Pages 3-38 and 3-39**
Discount Symbol **22CD**

**Convertible Loadcenters MCB or MLO — Base Units and Main Devices
10,000/35,000 Amperes Interrupting Capacity**

Complete assembly consists of: Loadcenter, Cover, and either Main Breaker Kit or Main Lug Kit.

Table 3-12. Indoor — Single-Phase — 3-Wire — 120/240 V — Factory Bonded Split Neutral — Top or Bottom Feed

Maximum		Box Size	Loadcenter Box and Panel		Loadcenter Cover		Main Lug Kit			Main Breaker Kit				
Main Ampere Rating	Number of Single Poles		Catalog Number ①②	Price U.S. \$	Combination	Surface	Price U.S. \$	Wire Size	Catalog Number	Price U.S. \$	kAIC Rating	Wire Size	Catalog Number	Price U.S. \$
125	22	C	CH22N125C		CH8CF	CH8CS		#10 – 1/0	CHL125N		10	#10 – 1/0	CH2100N ③ CH2125N ③	
200	32	J	CH32N200J		CH8JF	CH8JS		#4 – 300 kcmil	CHL225N		25	#2 – 300 kcmil	CSH2125N ④⑤ CSH2150N ④⑤ CSH2175N ④⑤ CSH2200N ④⑤	
225	42	K	CH42N225K		CH8KF	CH8KS		#4 – 300 kcmil	CHL225N		25	#2 – 300 kcmil	CSH2125N ④⑤ CSH2150N ④⑤ CSH2175N ④⑤ CSH2200N ④⑤ CSH2225N ④⑤	

- ① Panel does not include main. Order main breaker or main lug kit separately.
 - ② Loadcenters are factory bonded for service entrance applications. Remove bonding strap for separate neutral and ground bars for sub-feed applications.
 - ③ Hold down kit included.
 - ④ 35,000 AIC series combination rating is obtained when Types CH, CHT and CHP branch breakers are used with CSR main.
 - ⑤ CSH breakers include line lugs only as standard.
- Note:** Interrupting rating depends on main circuit breaker selected.

Table 3-13. Outdoor — Single-Phase — 3-Wire — 120/240 V — Insulated/Bondable Neutral

Maximum		Box Size	Loadcenter Box and Panel		Main Lug Kit			Main Breaker Kit			
Main Ampere Rating	Number of Single Poles		Catalog Number ⑥	Price U.S. \$	Wire Size	Catalog Number	Price U.S. \$	kAIC Rating	Wire Size	Catalog Number	Price U.S. \$
200	8	E	CH8N200RF ⑦⑧		#4 – 300 kcmil	CHL225N		25	#2 – 300 kcmil	CSH2125N CSH2150N CSH2175N CSH2200N	
125	2 2	C	CH22N125R ⑦		#10 – 1/0	CHL125N		10	#10 – 1/0	CH2100N ⑨ CH2125N ⑨	
200	3 2	J	CH32N200R ⑦		#4 – 300 kcmil	CHL225N		25	#2 – 300 kcmil	CSH2125N ⑩⑪ CSH2150N ⑩⑪ CSH2175N ⑩⑪ CSH2200N ⑩⑪	
225	4 2	K	CH42N225R ⑦		#4 – 300 kcmil	CHL225N		25	#2 – 300 kcmil	CSH2125N ⑩⑪ CSH2150N ⑩⑪ CSH2175N ⑩⑪ CSH2200N ⑩⑪ CSH2225N ⑩⑪	

- ⑥ Panel does not include main. Order main breaker or main lug kit separately.
- ⑦ Rainproof panels are furnished with hub closure plates. For rainproof hubs, refer to **Page 3-24**.
- ⑧ Includes feed-through lugs for both phase and neutral conductors.
- ⑨ Hold down kit included.
- ⑩ 35,000 AIC series combination rating is obtained when Types CH, CHT and CHP branch breakers are used with CSR main.
- ⑪ CSH breakers include line lugs only as standard.

Spa Panels

Table 3-14. Spa Panels Single-Phase 3-Wire — 120/240 Vac Insulated/Bondable Neutral — Factory Installed Ground Bar

Main Ampere Rating	Circuit Breaker Included	Enclosure Type	Type of Trim Included	Box Size	Wire Size Range Cu/Al 60°C or 75°C for Main Lugs	Catalog Number	Price U.S. \$
30	CH230GF	Outdoor	—	5R	#14 – 1/0	CH30SPA ⑫	
40	CH240GF	Outdoor	—	5R	#14 – 1/0	CH40SPA ⑬	
50	CH250GF	Outdoor	—	5R	#14 – 1/0	CH50SPA ⑭	
60	CH260GF	Outdoor	—	5R	#14 – 1/0	CH60SPA ⑮	

- ⑫ Includes a CH230GFI breaker, factory installed, and 2 extra circuits for convenience.
- ⑬ Includes a CH240GFI breaker, factory installed, and 2 extra circuits for convenience.
- ⑭ Includes a CH250GFI breaker, factory installed, and 2 extra circuits for convenience.
- ⑮ Includes a CH260GFI breaker, factory installed, and 2 extra circuits for convenience.



CH Spa Panel



Cutler-Hammer Quick-Pro™
All you need to know to save time and make more money. Specified on certain Cutler-Hammer products, the Quick-Pro symbol allows for immediate recognition of products that are designed for straightforward installation. When you see Quick-Pro, you know you can install quickly — sometimes up to 50% less than the usual installation time — and move onto your next job.

Box Sizes **Pages 3-38 and 3-39**
Discount Symbol **22CD**

Single-Phase and 3-Phase Circuit Breaker Unit Enclosures — 10,000/35,000 Amperes Interrupting Capacity



Circuit Breaker Unit Enclosures



CSH2200N

3

Table 3-15. Type ECB Circuit Breaker Unit Enclosure — Order Type CSR Circuit Breaker Separately — Unit Enclosure Includes Lug Tree Kit

Main Ampere Rating	Unit Enclosure Type	Mounting	Type of Circuit Breaker	Wire Size Range Cu/Al 60°C or 75°C	Catalog Number	Price U.S. \$
Single-Phase 3-Wire — 240 Vac Maximum						
150	Outdoor	—	CSR (included) ①	④	ECB150RB ⑤⑥⑦	
200	Outdoor	—	CSR (included) ②	④	ECB200RB ⑤⑥⑦	
225	Indoor	Flush	CSR ③	④	ECB225F ③⑥⑦	
	Indoor	Surface	CSR ③	④	ECB225S ③⑥⑦	
	Outdoor	—	CSR ③	④	ECB225R ③⑤⑥⑦	

- ① CSR2150N factory installed circuit breaker.
- ② CSR2200N factory installed circuit breaker.
- ③ Order circuit breaker separately.
- ④ Wire size is determined by the circuit breaker installed in enclosure. Maximum wire size and ampere rating is determined by **Table 3-19**.
- ⑤ Rainproof panels are furnished with hub closures plates. For rainproof hubs, refer to **Page 3-24**.
- ⑥ One ground lug accepting (1) #14 – #2 is factory installed. Also, there are pre-drilled holes to accept a GBK5 ground bar.
- ⑦ Approved for service entrance.

Table 3-16. Type CSH Circuit Breakers 120/240 Vac — 35,000 AIC For Use in Type ECB Unit Enclosures

Ampere Rating	Wire Size Range Cu/Al 60°C or 75°C for Line Terminals	2-Pole Breakers 35,000 AIC	
		Catalog Number	Price U.S. \$
100	#2 – 300 kcmil	CSH2100N	
125		CSH2125N	
150		CSH2150N	
175		CSH2175N	
200		CSH2200N	
225		CSH2225N	

Table 3-17. Shunt Trips

Description Type	Volts	Catalog Number Suffix Adder ⑥	Price U.S. \$ Adder Each
CSH	24	SR24	
CSH	120	SR01	

⑥ Add suffix indicated to end of breaker catalog number.

Table 3-18. CSR Lug Tree Kit For Replacement Purposes Only For Use in Type ECB Unit Enclosures

Ampere Rating	Description	Wire Size Range Cu/Al 60°C or 75°C for Line Terminals	Catalog Number	Price U.S. \$
225	For use on 125, 150, 175, 200 and 225 Ampere CSR Breakers	#2 – 300 kcmil	MCBK225	

Table 3-19. Wire Data

Wire/Application	Maximum Wire Size	Maximum Ampere Rating
Aluminum — Standard	250 kcmil	200
Aluminum — Service Entrance	250 kcmil	225
Copper — Standard and Service Entrance	250 kcmil	225

Product Selection

Table 3-20. Type ECC Circuit Breaker Unit Enclosure — Order Type CC Circuit Breaker Separately

Main Ampere Rating	Unit Enclosure Type	Mounting	Type of Circuit Breaker	Wire Size Range Cu/Al 60°C or 75°C	Catalog Number	Price U.S. \$
Single-Phase 3-Wire — 240 Vac Maximum						
225	Indoor	Flush	CC ①	②	ECC225F ①③④	
225	Indoor	Surface	CC ①	②	ECC225S ①③④	
225	Outdoor	—	CC ①	②	ECC225R ①③④⑤	

- ① Order circuit breaker separately.
- ② Wire size is determined by the circuit breaker installed in enclosure. Maximum wire size and ampere rating is determined by **Table 3-22**.
- ③ One ground lug accepting (1) #14 – #2 is factory installed. Also, there are pre-drilled holes to accept a GBK5 ground bar.
- ④ Approved for service entrance.
- ⑤ Rainproof panels are furnished with hub closures plates. For rainproof hubs, refer to **Page 3-24**.

Table 3-21. Type CC Circuit Breakers 240 Vac — 10,000 AIC For Use in Type ECC Unit Enclosures

Ampere Rating	Wire Size Range Cu/Al 60°C or 75°C for Line Terminals	Type CC 10,000 AIC	
		Catalog Number	Price U.S. \$
2-Pole			
100 125 150	#4 – 4/0	CC2100 CC2125 CC2150	
175 200 225	#2/0 – 300 kcmil	CC2175 CC2200 CC2225	
3-Pole			
100 125 150	#4 – 4/0	CC3100 CC3125 CC3150	
175 200 225	#2/0 – 300 kcmil	CC3175 CC3200 CC3225	

Table 3-22. Wire Data

Wire/Application	Maximum Wire Size	Maximum Ampere Rating
Aluminum — Standard	250 kcmil	200
Aluminum — Service Entrance	250 kcmil	225
Copper — Standard and Service Entrance	250 kcmil	225

Table 3-23. Shunt Trips, Auxiliary and Alarm Contacts

Description		Catalog Number Suffix Adder ⑥	Price U.S. \$ Adder Each
Type	Volts		
Shunt Trip			
CC	12 dc	SR12	
CC	24 dc	SR24	
CC	120 ac	SR01	
CC	208 ac	SR08	
CC	240 ac	SR02	
Auxiliary Contact			
CC (1) NO and (1) NC	—	AL1	
Alarm Contact			
CSR	—	CR1	

- ⑥ Add suffix indicated to end of breaker catalog number.

Type CH Surge Loadcenters

Product Description

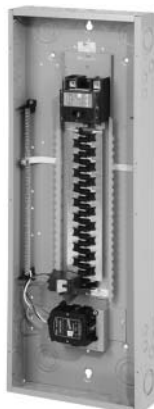

Surge Panel

The Type CH Surge Loadcenter includes a factory-mounted and wired surge suppressor device. There is a knockout in the cover which allows the user to view the status indication lights on the surge suppressor. The CH Surge Loadcenter reduces the surge current, helping protect sensitive home electronic equipment.



Save labor by installing factory-mounted surge suppression.

Ratings

- Loadcenter
 - 35 kAIC main breaker, main lug only, and convertible main breaker/main lug
 - Factory installed or provision for field installed surge suppressor
 - Top or bottom feed
- Surge Suppressor (CHSPULTRA)
 - Total joules: 3,500 joules
 - Maximum surge current: 175,000 amperes
 - Per phase (L-N/L-G) Surge Current: 75,000 amperes
 - Warranty: Lifetime
 - Connected equipment warranty: \$75,000

Table 3-24. Single-Phase Main Circuit Breaker Loadcenters with Factory Installed Surge Suppression — Indoor Single-Phase 3-Wire — 120/240 Vac — Factory Bonded Split Neutral

Main Breaker Type	Maximum Main Ampere Rating	Maximum Number 3/4-Inch (19.1 mm) Single Poles	Box Size	Wire Range Size	Loadcenter			Loadcenter Cover					
					UPC Code 782116	Catalog Number	Price U.S.\$	Combination ①			Surface		
								Catalog Number	UPC Code 782116	Price U.S.\$	Catalog Number	UPC Code 782116	Price U.S.\$
CSH 35 kAIC	100	24	E	#6 – 4/0	200054	CHSUR24B100E		CHSUR8EF	200221		CHSUR8ES	200269	
		32	K		200078	CHSUR32B100K		CHSUR8KF	200238		CHSUR8KS	200276	
	150	32	K	#2 – 300	200085	CHSUR32B150K		CHSUR8KF	200238		CHSUR8KS	200276	
	200	32	K	kcmil	200108	CHSUR32B200K		CHSUR8KF	200238		CHSUR8KS	200276	
	200	42	L		320196	CHSUR42B200L2		CHSUR8LF	200245		CHSUR8LS	200283	

① Combination style covers may be used for surface or flushmount applications.

Table 3-25. Single-Phase Main Lug Loadcenters with Factory Installed Surge Suppression — Indoor Single-Phase 3-Wire — 120/240 Vac — Twin Neutral — Factory Installed Ground Bar

Maximum Main Ampere Rating	Maximum Number 3/4-Inch (19.1 mm) Single Poles	Box Size	Wire Range Size	Loadcenter			Loadcenter Cover					
				UPC Code 782116	Catalog Number	Price U.S.\$	Combination ②			Surface		
							UPC Code 782116	Catalog Number	Price U.S.\$	UPC Code 782116	Catalog Number	Price U.S.\$
125	24	E	#6 – 2/0	200061	CHSUR24L125E		200221	CHSUR8EF		200269	CHSUR8ES	
225	32	K	#2 – 300	200092	CHSUR32L225K		200238	CHSUR8KF		200276	CHSUR8KS	
	42	L	kcmil	320202	CHSUR42L225L2		200245	CHSUR8LF		200283	CHSUR8LS	

② Combination style covers may be used for surface or flushmount applications.

Table 3-26. Single-Phase Convertible Loadcenters with Factory Installed Surge Suppression — Indoor (order main breaker kit separately) Single-Phase 3-Wire — 120/240 Vac — Twin Neutral — Factory Installed Ground Bar

Maximum Main Ampere Rating	Maximum Number 3/4-Inch (19.1 mm) Single Poles	Box Size	Wire Range Size	Loadcenter			Loadcenter Cover					
				UPC Code 782116	Catalog Number	Price U.S.\$	Combination ③			Surface		
							UPC Code 782116	Catalog Number	Price U.S.\$	UPC Code 782116	Catalog Number	Price U.S.\$
225	32	K	#2 – 300	200115	CHSUR32N225K		200238	CHSUR8KF		200276	CHSUR8KS	
	42	L	kcmil	320004	CHSUR42N225L		200245	CHSUR8LF		200283	CHSUR8LS	

③ Combination style covers may be used for surface or flushmount applications.

Type CH Surge Loadcenters

3

Table 3-27. Single-Phase Main Circuit Breaker Loadcenters with Field Installation Provision for Surge Suppression — Indoor Single-Phase 3-Wire — 120/240 Vac — Factory Bonded Split Neutral

Main Breaker Type	Maximum Main Ampere Rating	Maximum Number 3/4-Inch (19.1 mm) Single Poles	Box Size	Wire Range Size	Loadcenter			Loadcenter Cover					
					UPC Code 782116	Catalog Number	Price U.S.\$	Combination ①			Surface		
								UPC Code 782116	Catalog Number	Price U.S.\$	UPC Code 782116	Catalog Number	Price U.S.\$
CSH 35 kAIC	100	24	E	#6 – 4/0	CHEC24B100E	200139		200221	CHSUR8EF		200269	CHSUR8ES	
		32			CHEC32B100K	200153		200238	CHSUR8KF		200276	CHSUR8KS	
	150 200 200	32 32 42	K K L	#2 – 300 kcmil	CHEC32B150K CHEC32B200K CHEC42B200L	200160 200252 200184		200238 200238 200245	CHSUR8KF CHSUR8KF CHSUR8LF		200276 200276 200283	CHSUR8KS CHSUR8KS CHSUR8LS	

① Combination style covers may be used for surface or flushmount applications.

Table 3-28. Single-Phase Main Lug Loadcenters with Field Installation Provision for Surge Suppression — Indoor Single-Phase 3-Wire — 120/240 Vac — Twin Neutral — Factory Installed Ground Bar

Maximum Main Ampere Rating	Maximum Number 3/4-Inch (19.1 mm) Single Poles	Box Size	Wire Range Size	Loadcenter			Loadcenter Cover					
				UPC Code 782116	Catalog Number	Price U.S.\$	Combination ②			Surface		
							UPC Code 782116	Catalog Number	Price U.S.\$	UPC Code 782116	Catalog Number	Price U.S.\$
125	24	E	#6 – 2/0	200146	CHEC24L125E		200221	CHSUR8EF		200269	CHSUR8ES	
225	32 42	K L	#2 – 300 kcmil	200177	CHEC32L225K		200238	CHSUR8KF		200276	CHSUR8KS	
				200191	CHEC42L225L		200245	CHSUR8LF		200283	CHSUR8LS	

② Combination style covers may be used for surface or flushmount applications.

Table 3-29. Single-Phase Convertible Loadcenters with Field Installation Provision for Surge Suppression — Indoor Single-Phase 3-Wire — 120/240 Vac — Twin Neutral — Factory Installed Ground Bar

Maximum Main Ampere Rating	Maximum Number 3/4-Inch (19.1 mm) Single Poles	Box Size	Wire Range Size	Loadcenter			Loadcenter Cover					
				UPC Code 782116	Catalog Number	Price U.S.\$	Combination ③			Surface		
							UPC Code 782116	Catalog Number	Price U.S.\$	UPC Code 782116	Catalog Number	Price U.S.\$
225	32 42	K L	#2 – 300 kcmil	200207	CHEC32N225K		200238	CHSUR8KF		200276	CHSUR8KS	
				200214	CHEC42N225L		200245	CHSUR8LF		200283	CHSUR8LS	

③ Combination style covers may be used for surface or flushmount applications.

Table 3-30. Main Breaker Kits

Maximum Main Ampere Rating	UPC Code 78211	Catalog Number	Price U.S.\$
100	6318889	CSH2100N	
150	3099743	CSH2150N	
200	3099767	CSH2200N	
225	3099774	CSH2225N	

Table 3-31. Main Lug Kits

Maximum Main Ampere Rating	UPC Code 78211	Catalog Number	Price U.S.\$
125	3098579	CHL125N	
225	3098487	CHL225N	

Product Description

Type CH Renovation Loadcenter

3

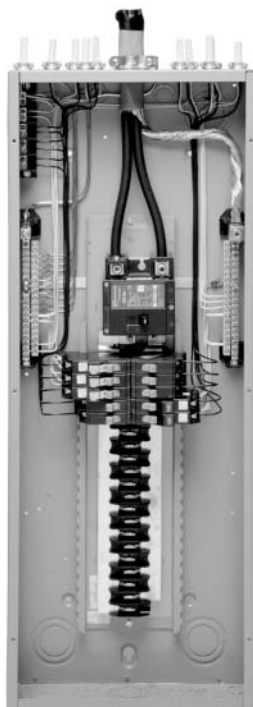

Renovation Panel

Product Description

The Cutler-Hammer Renovation Loadcenter by Eaton Corporation is designed for the service contractor. With the addition of a 5-circuit terminal block factory mounted in the top left corner of the loadcenter, the service contractor can terminate short circuit wires instead of having to use expensive wire nuts. Also, the Renovation Loadcenter incorporates a twin stacked neutral design that places the neutral and ground terminations higher in the loadcenter. Both of these features were added without increasing any size from a standard loadcenter. These features will eliminate the need for wire nuts and make for a much neater installation. There is a provision to field mount a second 5-circuit terminal block (RN5TB) in the top right corner of the loadcenter. Choose amongst Cutler-Hammer Type CH breaker family for use in the Renovation Panel.

Single-Phase — Main Circuit Breaker Loadcenters
35,000 Amperes Interrupting Capacity ②

Table 3-32. Single-Phase, 3-Wire — 120/240 Vac — Factory Bonded Stacked Split Neutral

Main Breaker Type	Main Ampere Rating	Max. Number 3/4-Inch (19.1 mm) Poles	Enclosure Type	Box Size	Wire Size Range Cu/Al 60 or 70°C for Main Breakers	Loadcenter Catalog Number	Price U.S. \$	Cover Catalog Number ①		Price U.S. \$
								Combination	Surface	
CH	100	20	Indoor	C	#6 – 1/0	CH22B100CRN		CH8CFF	CH8CS	
CSH	150	32	Indoor	J	#2 – 300 kcmil	CH32B150JRN		CH8JF	CH8JS	
CSH	200	32	Indoor	J	#2 – 300 kcmil	CH32B200JRN		CH8JF	CH8JS	
CSH	200	42	Indoor	K	#2 – 300 kcmil	CH42B200KRN		CH8KF	CH8KS	

① Combination style covers may be used in surface or flush applications.

② 100 ampere main breaker is rated 10 kAIC.

Note: All main circuit breaker loadcenters are listed for use as service entrance equipment. Loadcenters are factory bonded for service entrance applications. Remove bonding strap for separate neutral and ground bars for sub-feed applications.

Branch Circuit Breakers (CH)

See Pages 3-2 – 3-23.

Table 3-33. Renovation Loadcenter

Description	Catalog Number	Price U.S. \$
5-Circuit Terminal Block Kit Ground Bar Kits	RN5TB (See Page 3-64)	



Cutler-Hammer Quick-ProSM

All you need to know to save time and make more money. Specified on certain Cutler-Hammer products, the Quick-Pro symbol allows for immediate recognition of products that are designed for straightforward installation. When you see Quick-Pro, you know you can install quickly — sometimes up to 50% less than the usual installation time — and move onto your next job.

Product Description

Type CH Retrofit Interior Kits

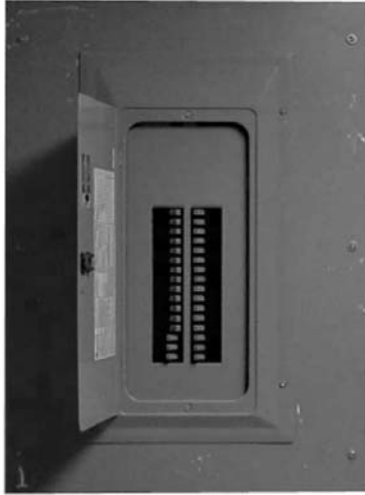

Type CH Retrofit Interior with Cover Assembly

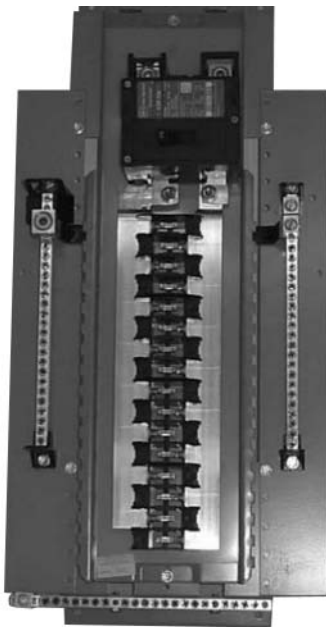

Type CH Retrofit Interior

Product Description

Replacing existing loadcenters and panelboards can be a time consuming and expensive job. CH retrofit kits can be the solution to save time and money. The kit consists of a standard trim to fit the interior, a picture frame trim to fit the existing box, and a field adjustable interior assembly which includes neutral and ground bars as well. These are especially applicable when the existing box is flush mounted in drywall, plaster or block wall. The existing box, and many times existing wiring, can remain. Interiors are UL recognized under UL 67, Panelboard standard.



Cutler-Hammer Quick-ProSM

All you need to know to save time and make more money. Specified on certain Cutler-Hammer products, the Quick-Pro symbol allows for immediate recognition of products that are designed for straightforward installation. When you see Quick-Pro, you know you can install quickly — sometimes up to 50% less than the usual installation time — and move onto your next job.

Detailed Product Guide

All standard retrofit kits are suitable for a range of existing box sizes:

- Box width ranging from 14.50 to 22.00 inches (368.3 to 558.8 mm).
- Box depth ranging from 4.25 inches (108.0 mm) for CH to 6.00 inches (152.4 mm).
- Box height ranging from 21.00 to 45.00 inches (533.4 to 1143.0 mm).

For box dimensions outside of these ranges, contact the **Lincoln Flex Center at 800-330-6479**. Be sure to provide the existing incoming line wire size.

To select the retrofit kit:

1. From the existing box size determine which retrofit groups are suitable (may be more than one).
2. Use type of interior, number of phases, and type of main to find the selection chart.
3. Select part number from chart (if main breaker, replace XXX with specific amp rating).
4. Note that the overlap of the existing wall is the retro cover size minus the existing box size. If specific measurements are needed, communicate that you need a custom trim size.
5. Contact the Lincoln Flex Center at 800-330-6479 for pricing, lead-times, and order entry instructions.

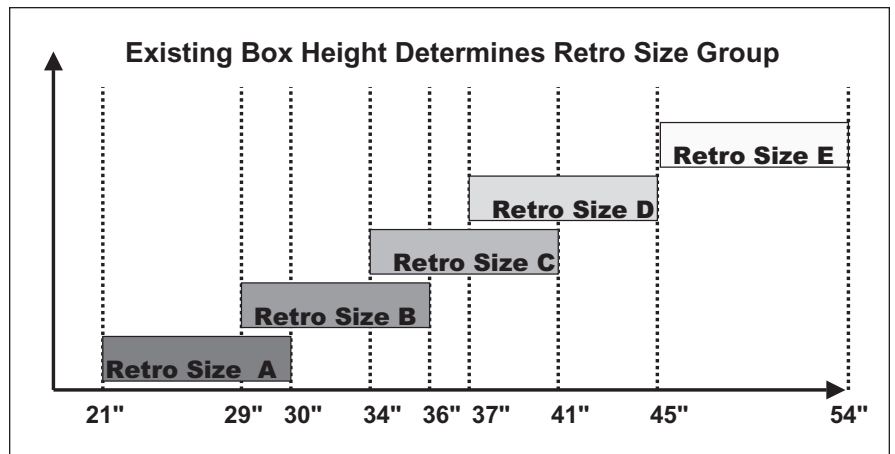

Figure 3-1. Retro Size Groups

Product Selection

Product Selection

Table 3-34. Type CH Interior — Dimensions in Inches (mm)

Main Breaker Rating		Existing Box Height		Wire Size	Number of Circuits	Part Number	Retro Size Group	Retro Cover Size ①	
Amperes	AIC	Minimum	Maximum					Height	Width
Single-Phase with Main Breaker									
60 – 125	10K	21.00 (533.4)	30.00 (762.0)	#2 – 1/0	22	RACH22BXXX ②	A	33.00 (838.2)	24.00 (609.6)
60 – 125	10K	29.00 (736.6)	36.00 (914.4)	#2 – 1/0	30	RBCH30BXXX ②	B	40.00 (1016.0)	24.00 (609.6)
100 – 200	25K	29.00 (736.6) 30.50 (774.7)	30.00 (762.0) 36.00 (914.4)	#2 – 250 kcmil #2 – 300 kcmil	24	RBCH24BXXX ②			
100 – 225	25K	34.00 (863.6)	41.00 (1041.4)	#2 – 300 kcmil	32	RCCH32BXXX ②	C	43.00 (1092.2)	24.00 (609.6)
100 – 225	25K 100K	37.00 (939.8)	45.00 (1143.0)	#2 – 300 kcmil #4 – 300 kcmil	42	RDCH42BXXX ② RDCH42HXXX ②	D	47.00 (1193.8)	24.00 (609.6)
Three-Phase with Main Breaker									
60 – 125	10K	21.00 (533.4)	30.00 (762.0)	#2 – 1/0	18	RACH18B3XXX ②	A	33.00 (838.2)	24.00 (609.6)
100 – 225	10K	37.00 (939.8)	45.00 (1143.0)	#2/0 – 300 kcmil	42	RDCH42B3XXX ②	D	47.00 (1193.8)	24.00 (609.6)
	100K	37.00 (939.8) 39.00 (990.6)	38.50 (977.9) 45.00 (1143.0)	#2/0 – 250 kcmil #2/0 – 300 kcmil		RDCH42H3XXX ②			

① Specific cover sizes are available. Be sure to specify the custom cover option and provide exact dimensions required.

② XXX is for Main Breaker specific ampere rating.

Table 3-35. Type CH Interior — Dimensions in Inches (mm)

Maximum Bus Ampere Rating	Existing Box Height		Wire Size	Number of Circuits	Part Number	Retro Size Group	Retro Cover Size ③	
	Minimum	Maximum					Height	Width
Single-Phase Main Lug Only								
125	21.00 (533.4)	30.00 (762.0)	#4 – 2/0	24	RACH24L125	A	33.00 (838.2)	24.00 (609.6)
125	25.00 (635.0) 26.50 (673.1)	30.00 (762.0) 30.00 (762.0)	#4 – 1	42	RBCH42L125	B	40.00 (1016.0)	24.00 (609.6)
	225	29.00 (736.6)	36.00 (914.4)	#4 – 1/0	32			
225	28.50 (723.9)	36.00 (914.4)	#1 – 300 kcmil	42	RBCH42L225			
225	34.00 (863.6)	41.00 (1041.4)	#4 – 4/0	42	RCCH42L225	C	43.00 (1092.2)	24.00 (609.6)
225	37.00 (939.8)	45.00 (1143.0)	#1 – 300 kcmil	42	RDCH42L225	D	47.00 (1193.8)	24.00 (609.6)
Single-Phase with Sub-Feed Lugs								
225	29.00 (736.6)	31.00 (787.4)	#1 – 300 kcmil	24	RBCH24D225	B	40.00 (1016.0)	24.00 (609.6)
225	31.00 (787.4) 34.00 (863.6)	33.50 (850.9) 36.00 (914.4)	#1 – 300 kcmil #1 – 300 kcmil	30	RBCH30D225			
225	34.00 (863.6)	41.00 (1041.4)	#4 – 4/0	32	RCCH32D225	C	43.00 (1092.2)	24.00 (609.6)
225	37.00 (939.8)	45.00 (1143.0)	#1 – 300 kcmil	42	RDCH42D225	D	47.00 (1193.8)	24.00 (609.6)
Three-Phase Main Lug Only								
125	21.00 (533.4)	30.00 (762.0)	#6 – 2/0	24	RACH24L3125	A	33.00 (838.2)	24.00 (609.6)
125	22.00 (558.8)	30.00 (762.0)	#4 – #1	30	RACH30L3125			
150	22.50 (571.5)	30.00 (762.0)	#4 – 1/0	30	RACH30L3225			
225	24.50 (622.3)	30.00 (762.0)	#4 – 4/0					
225	29.00 (736.6)	36.00 (914.4)	#4 – 300 kcmil	30	RBCH30L3225	B		
125	25.00 (635.0)	28.00 (711.2)	#4 – #1	42	RBCH42L3125			
225	28.50 (723.9)	36.00 (914.4)	#4 – 4/0	42	RBCH42L3225			
225	34.00 (863.6)	41.00 (1041.4)	#4 – 300 kcmil	42	RCCH42L3225	C		
225	37.00 (939.8)	45.00 (1143.0)	#4 – 300 kcmil	42	RDCH42L3225	D		
Three-Phase with Sub-Feed Lugs								
225	29.00 (736.6)	36.00 (914.4)	#6 – 300 kcmil	24	RBCH24D3225	B	40.00 (1016.0)	24.00 (609.6)
	225	31.00 (787.4) 34.00 (863.6)	33.50 (850.9) 36.00 (914.4)	#6 – 250 kcmil #6 – 300 kcmil	30			
225	34.00 (863.6)	41.00 (1041.4)	#6 – 300 kcmil	30	RCCH30D3225	C	43.00 (1092.2)	24.00 (609.6)
225	37.00 (939.8)	45.00 (1143.0)	#6 – 300 kcmil	42	RDCH42D3225	D	47.00 (1193.8)	24.00 (609.6)

③ Specific cover sizes are available. Be sure to specify the custom cover option and provide exact dimensions required.

Loadcenter Options and Accessories



CHSF2125



CHFP



CHRLS



CHSF3125



BINA



TDL

Table 3-36. Field Installation and Parts

Number of Poles	Ampere Rating	Number of 3/4-Inch (19.1 mm) Spaces Needed	Ordering Quantity ①	Catalog Number	Price U.S. \$
Sub-Feed Lug Blocks					
2	125	2	1	CHSF2125	
3	125	3		CHSF3125	
Neutral/Ground Lug Add-on Neutral or Ground Lug			1	NL20 NL30 NL300	
Filler Plates 3/4-inch (19.1 mm) Space Circuit Breaker Space			25	CHFP	
CSR Main Circuit Breaker Filler Plate (with Hardware)			1	CSRFP	
Door Lock — 12 - 42 Circuits, and 100 – 225 Amperes			1	TDL	
Sandlewood Spray Paint			1	SPCSW	
ANSI-61 Light Gray Touchup Paint for Outdoor Loadcenters			1	SPC61	
Isolated Neutral Assembly (Computer Circuits)			1	BINA	
Circuit Directory — Adhesive Backed			10	TCD	
Cover Screws			25	LCCS	
Cover Replacement Latch 14-5/16 inch (363.55 mm) Wide Loadcenters Only			1	CHRLS	
Circuit Marking Strip (Next to Breakers)			10	CHMS	
Circuit Identification Label (Preprinted Breaker Labels Next to Breakers)			25	CHBL	
Series Rated Caution Label			25	SRL	
Branch Circuit Numbering Strip			20	CHNS	
Bonding Strap with Screw			1	BSSUSE	

① Must be purchased in multiples of ordering quantities indicated.

Accessories

3

Table 3-37. Field Installation Rainproof Conduit Hubs

Description	Conduit Size		Ordering Quantity ^①	Catalog Number	Price U.S. \$
	Inches	mm			
Group 1 — For use with 70, 100 and 125 ampere MLO and MCB Loadcenters and Circuit Breaker Enclosures and the following 150 and 200 ampere panels: CH8B150RF CH8B200RF	.75	19.1	1	DS075H1	
	1.00	25.4	1	DS100H1	
	1.25	31.8	1	DS125H1	
	1.50	38.1	1	DS150H1	
	2.00	50.8	1	DS200H1	
Group 2 — For use with 150, 200 and 225 ampere MLO and MCB Loadcenters and Circuit Breaker Enclosure except for the following 150 and 200 ampere panels: CH8B150RF, CH8B200RF	2.00	50.8	1	DS200H2	
	2.50	63.5	1	DS250H2	
	3.00	76.2	1	DS300H2	
Adapter Kit — Allows Installing a Group 1 Hub on Devices Arranged for Group 2 Hubs	—	—	1	DS900AP	
Group 1 — Small Blank Hub Closure Plate	—	—	1	DS900CP1	
Group 2 — Large Blank Hub Closure Plate	—	—	1	DS900CP2	

^① Must be purchased in multiples of ordering quantities indicated.



DS100H1

Table 3-38. Ground Bar Kits

Description (See Legend)	Length		Ordering Quantity ^②	Catalog Number	Price U.S. \$
	Inches	mm			
	2.54	64.5	1	GBK5 ^②	
	3.59	91.2	1	GBK520 ^②	
	4.29	109.0	1	GBK10 ^②	
	5.34	135.6	1	GBK1020 ^②	
	4.61	117.1	1	GBK13 ^②	
	5.69	144.5	1	GBK14 ^②	
	6.74	171.2	1	GBK1420 ^②	
	8.14	206.8	1	GBK21 ^②	
	9.19	233.4	1	GBK2120 ^②	
	7.94	201.7	1	CH9GP21 ^{③④}	



GBK14

Ground Bar Legend

- = (3) #14 – #10 Cu/Al or (1) #14 – #4 Cu/Al
- = (1) #6 – 2/0 Cu/Al
- ▣ = (1) 1/0 – 14 or (3) #10 – 12 Cu/Al
- ◐ = (1) #14 – 1/0 Cu/Al or (3) #14 – #10 Cu/Al
- = Mounting Hole

^② Distance between mounting holes is 1-3/4 inches (44.5 mm).

^③ For single- and 3-phase 400 ampere loadcenters.

^④ Distance between mounting holes is 2-13/32 inches.

Table 3-39. Grounded "B" Phase Adapters

Maximum Amperes	3-Phase Loadcenter Types of Panels	Kit Catalog Number ^⑤	Price U.S. \$
125	12 – 32 Circuit Main Lug	CHGRD1	
225	Main Lug and CHH Main Breaker Panels CC Main CB Panels	CHGRD2 CHGRD3	

^⑤ Cannot be used in Safety Breaker Panels. Classic Plus Panels only.

Table 3-40. Neutral Bar Accessories

Description	Catalog Number ^⑥	Price U.S. \$
Split Neutral Kit for 22 Circuit 125 A Maximum	CHSN125C	
Split Neutral Kit for 32 Circuit 200 A Maximum	CHSN225J	
Split Neutral Kit for 42 Circuit 200 A Maximum	CHSN225K	
Replacement Neutral for all C Type Boxes	CHN125C	
Replacement Neutral for all D Type Boxes	CHN125D	
Replacement Neutral for all L Type Boxes	CHN225L	
Isolated Neutral Assembly (Computer Circuits)	BINA	

^⑥ Cannot be used in Safety Breaker Panels. Classic Plus Panels only.

Accessories

Mechanical Interlock Covers

Covers mechanically interlock two breakers. Type A covers interlock two CH breakers mounted across from one another. Type B covers interlock a main Type CSR Breaker with a Type CH.



CH8BRM Type A



CH8EFM Type B

Table 3-41. Mechanically Interlocks

Type	Fits Loadcenter Catalog Numbers	Mechanical Interlock Panel Cover			
		Catalog Number	Price U.S. \$	Catalog Number	Price U.S. \$
		Flush		Surface	
A	CH12L125B, CH16L125B, CH12L3125B, CH14B100B CH20L125C, CH24L125C, CH18L3125C, CH24L3125C, CH22B100C, CH22N100C CH24L150D, CH32L150D, CH24L3225D, CH30L3150D CH42L225G, CH42L3225G	CH8BFM CH8CFM CH8DFM CH8GFM		CH8BSM CH8CSM CH8DSM CH8GSM	
	Inner Cover of Box B Raintight Inner Cover of Box C Raintight	— —		CH8BRM CH8CRM	
	B	CH24B150E, CH24B200E CH32B150J, CH32B200J, CH3242B200J, CH32N200J, CH32B225J CH42B200K, CH42N200K, CH42B225K	CH8EFM CH8JFM CH8KFM		CH8ESM CH8JSM CH8KSM
	CHPC32B150L, CHPC32B200L, CHPC32N200L CHPC42B150L, CHPC42B200L, CHPC42N200L	CHPC8B32LFM CHPC8B42LFM		— —	
	CH8B150RF, CH8B200RF, CH8N200RF, CH24B150R, CH24B200R CH32B150R, CH32B200R, CH32N200R, CH32B225R CH42B200R, CH42N200R, CH42B225R	CH3RDF7M CH3RDF9M CH3RDF10M		— — —	

Note: For interlock covers for loadcenters not listed in chart, please contact the Flex Center at 1-800-330-6479.

Decorator Cover Accessory

- For easy use with CH Loadcenters mounted in living space.
- Easily wallpapered or painted to match any decor.
- Patented Loadcenter accessory — exclusively from Eaton.

Table 3-42. Decorator Cover Accessory

Catalog Number	
Corresponding Cover	Existing CH Loadcenter Cover
CH8BF CH8CF CH8DF/EF CH8GF/JF CH8KF	CH8KDNB CH8KDNC CH8KDND CH8KDNI CH8KDNJ CH8KDNI



Now you see it . . .

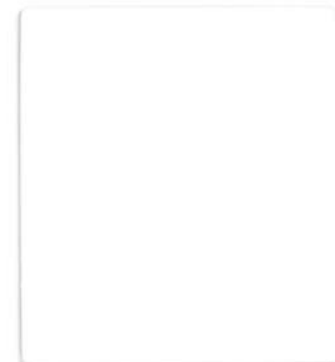

. . . Now you don't.

Product Selection

CH Loadcenter Goof Collars

Don't let an ugly drywall problem ruin a beautiful electrical installation.

and the drywall surrounding the panel is damaged. The collar allows 2 inches of overhang beyond the standard flush trim.

Currently available in three sizes for the CH style Loadcenters.

The Cutler-Hammer Goof Collar is designed to cover gaps between the finished drywall and loadcenter enclosure. This is often necessary when upgrading the electrical service



Before



After

3

Product Selection

Table 3-43. Goof Collars

Dimensions in Inches (mm)		Catalog Number		Price U.S. \$
Height	Width	Loadcenter Cover	Goof Collar	
26.00 (660.4)	19.00 (482.6)	CH8CF	CH8CFC1926	
39.00 (990.6)	19.00 (482.6)	CH8JF	CH8JFC1939	
42.00 (1066.8)	19.00 (482.6)	CH8KF	CH8KFC1942	

Goof Collars are also available for the BR style loadcenters upon request. Please contact the **Lincoln Flex Center at 1-800-330-6479** for questions and product opportunities.

Circuit Analyzer



Circuit Analyzer

Product Description

Eaton's Cutler-Hammer Circuit Analyzer provides accurate testing of AFCI and GFCI devices while also testing for faulty wiring conditions.

There are other testing devices on the market but this will be the only one available from an AFCI manufacturer. Eaton has more than 100 years of electrical control and power distribution experience, and a thorough understanding of what arc faults are all about. This experience with AFCI breakers led to developing a patented feature of the analyzer that will save contractors time and aggravation. It allows contractors to verify whether they have a grounded neutral simply by depressing the red Neutral Isolation test button. In this way, they will be able to determine whether they have a grounded neutral or have other neutrals connected before they leave the job site. Additionally, the Circuit Analyzer has a button that tests AFCI and two that test GFCI devices (both 40 mA and 8 mA).

Application Description

The Circuit Analyzer serves as a handy troubleshooting tool for contractors and electrical inspectors. It's a circuit analyzer that provides accurate testing of AFCI and GFCI devices while also testing for faulty wiring conditions.

Features, Functions and Benefits

- All-in-one tester for ground fault, arc fault and faulty wiring conditions.
- Neutral Isolation Test Button is a patented feature that allows the contractor to determine whether they have a grounded neutral or have other neutrals connected before leaving the job.
- Additional test button for AFCI and two that test GFCI devices (40 mA and 8 mA).
- Only product available from an AFCI manufacturer.
- Three standard accessories enhance the usefulness of the Circuit Analyzer:
 - An alligator clip attachment to test hardwired circuits, such as smoke detectors, that lack a receptacle. The clip simply is attached to the smoke alarm's terminals
 - An adapter (3-prong to 2-prong) for testing in older homes that lack 3-prong receptacles
 - Light socket adapter for AFCI testing when no receptacle is available. Examples are ceiling fans that contain sockets and recessed lighting
 - Additionally, the Circuit Analyzer comes with a black carrying case

Technical Data and Specifications

How it Works

1. Plug the tester (or one of the accessories) into the receptacle, light fixture or hardwired terminals to be tested.
2. Check the wiring LEDs on the Circuit Analyzer to determine if the circuit is wired correctly.
3. If the circuit is wired correctly, then proceed to test for Neutral Isolation, Arc Fault or Ground Fault conditions, depending on the breaker or receptacle type that is on the circuit.
4. To perform these tests, press the corresponding button on the Circuit Analyzer and review the results.

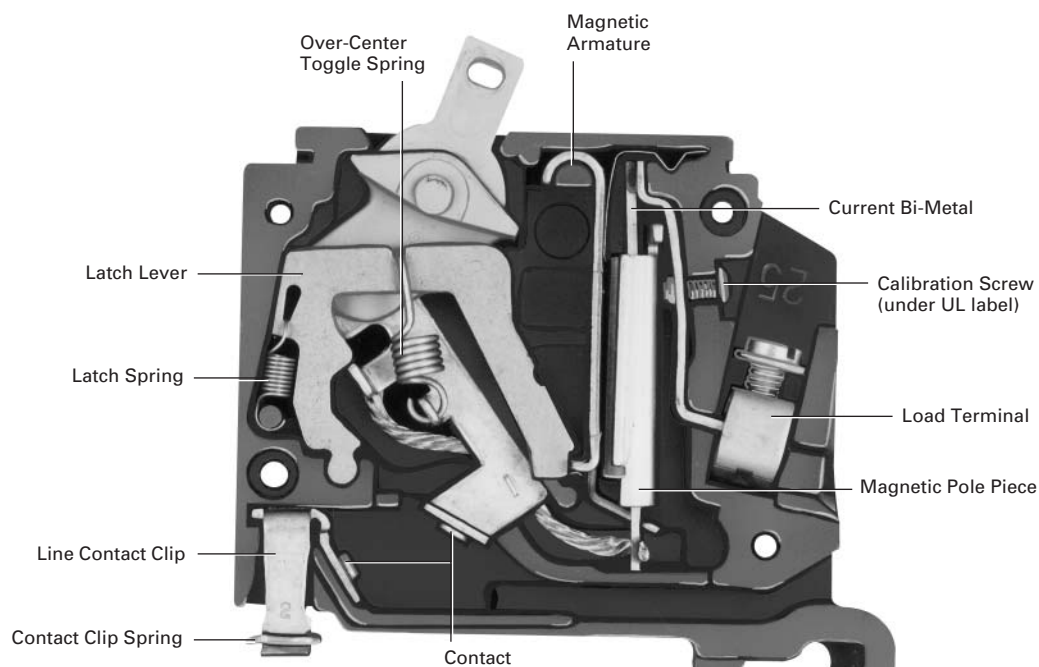

Plug-on Type CH Breaker

Extended Residential Warranty Highlights

Note: See Cutler-Hammer Publication Number SA-365 for complete details.

- Lifetime feeder breaker warranty.
- Lifetime loadcenter warranty.

Product Selection



Product Selection

Plug-on Circuit Breakers, Type CH
10,000 Amperes Interrupting
Capacity 120 Vac, 120/240 Vac
and 240 Vac



Plug-on Circuit Breakers

Table 3-44. Type CH Breakers, 3/4-Inch (19.1 mm) per Pole 120, 120/240 or 240 Vac, 10,000 AIC

Ampere Rating	Wire Size Range Cu/Al 60°C or 75°C	Catalog Number		
		1-Pole 120/240 Vac Requires One 3/4-Inch (19.1 mm) Space	2-Pole 120/240 Vac Common Trip Requires Two 3/4-Inch (19.1 mm) Spaces	3-Pole 240 Vac Common Trip Requires Three 3/4-Inch (19.1 mm) Spaces
				
		10 per Shelf Carton 10 kAIC	5 per Shelf Carton 10 kAIC	5 per Shelf Carton 10 kAIC
10	(1) #14 – 8 ①	CH110	CH210	CH310
15	(2) #14 – 10 ①②	CH115 ⑦⑧	CH215 ⑧	CH315 ⑧
20	(1) #14 – 6 ③	CH120 ⑦⑧	CH220 ⑧	CH320 ⑧
25		CH125 ⑧	CH225 ⑧	CH325 ⑧
30		CH130 ⑧	CH230 ⑧	CH330 ⑧
35	#14 – 2 ① #14 – 6 ③	CH135 ⑧	CH235 ⑧	CH335 ⑧
40	#10 – 1/0 ④	CH140 ⑧	CH240 ⑧	CH340 ⑧
45	#14 – 2 ⑤	CH145 ⑧	CH245 ⑧	CH345 ⑧
50	#3/0 ⑥	CH150 ⑧	CH250 ⑧	CH350 ⑧
60		CH160 ⑧	CH260 ⑧	CH360 ⑧
70		CH170	CH270	CH370
80		—	CH280	CH3080
90		—	CH290	CH3090
100		—	CH2100	CH3100
110		—	CH2110	—
125		—	CH2125	—
150		—	CH2150 ⑨	—

- ① For 1- and 2-pole breakers.
- ② Solid and stranded wire can be used together.
- ③ For 3-pole breakers.
- ④ 1-pole 60 – 70 amperes, 2-pole 80 – 125 amperes, 3-pole 40 – 100 amperes.
- ⑤ 1-pole 40 – 50 amperes, 2-pole 40 – 70 amperes.
- ⑥ 2-pole 150 amperes.
- ⑦ Switching duty rated.
- ⑧ HACR rated.
- ⑨ CH2150 requires 4-pole spaces and is not suitable for use on 3-phase panels, not CSA® certified.

Note: For factory installed options and pricing, refer to **Page 3-37**.

Plug-on Branch Feeder Type Arc Fault Circuit Breakers, Type CH 10,000 Amperes Interrupting Capacity 120 Vac and 120/240 Vac



Type CH 1-Pole AFCI Circuit Breaker

A Branch Feeder Type Arc Fault Circuit Interrupter is a device intended to mitigate parallel arcing faults in the complete circuit, including connected cords. Parallel arcing faults can occur from line to neutral or line to ground. These arcing faults are in parallel with the load and produce the most energy of all arcing faults.

The Branch Feeder Type AFCI is required in the 1999, 2002 and 2005 National Electrical Code.

As of January 1, 2008, the Combination Type AFCI is required.

Product Selection

Table 3-45. Type CH 3/4-Inch (19.1 mm) wide FIRE-GUARD™ AFCI Circuit Breakers

Poles	Ampere Rating	Configuration	Catalog Number
Single-Pole 10 kAIC	15	AFCI AFCI with GFCI	CH115AF ① CH115AFGF
	20	AFCI AFCI with GFCI	CH120AF ① CH120AFGF
Double-Pole 10 kAIC ②③	15	AFCI Common Trip AFCI Independent Trip AFCI Common Trip with GFCI	CH215AF CH215AFIT CH215AFGF
	20	AFCI Common Trip AFCI Independent Trip AFCI Common Trip with GFCI	CH220AF CH220AFIT CH220AFGF

① Clamshell packaging available with CS modification code on the end of catalog number.

② Common trip refers to 2-pole 240 volt load application sourced by 120/240 Vac (see **Figure 3-4**).

③ Independent trip refers to 2-pole multi-wire, home run or shared neutral circuits (see **Figure 3-3** and **Figure 3-5**).

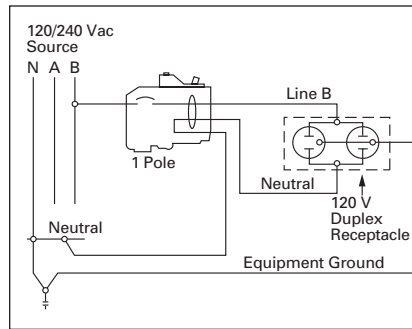

Figure 3-2. 1-Pole Single 120 Volt Load Application Sourced by 120/240 Vac

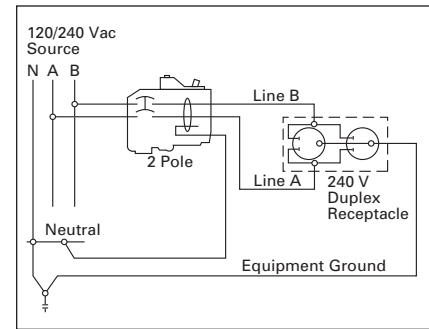

Figure 3-4. 2-Pole 240 Volt Load Application Sourced by 120/240 Vac

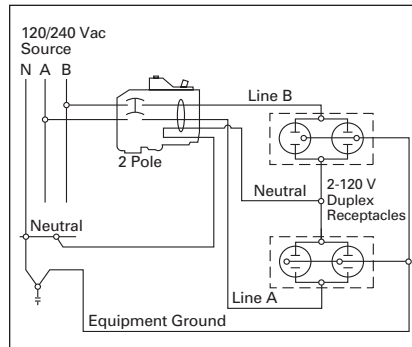

Figure 3-3. 2-Pole Shared Neutral with Multi-Duplex Receptacle Application

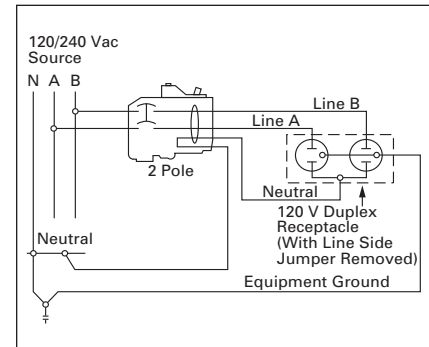

Figure 3-5. 2-Pole Shared Neutral with Duplex Receptacle Application

Plug-on Combination Type Arc Fault Circuit Breakers, Type CH 10,000 Amperes Interrupting Capacity 120 Vac and 120/240 Vac



Type CH 1-Pole AFCI Circuit Breaker

A Combination Type Arc Fault Circuit Interrupter is a device that includes all of the protection offered by the Branch Feeder AFCI (mitigation of parallel arcing faults in the complete circuit, including connected cords). In addition it provides direct detection of persistent low current arcing faults down to 5 amps with associated mitigation of fire hazards in the cords connected to the outlets. Parallel arcing faults can occur from line to neutral or line to ground. These arcing faults are in parallel with the load and produce the most energy of all arcing faults. The current level of low current arcing faults is limited by the load.

Product Selection

Table 3-46. Type CH 3/4-Inch (19.1 mm) wide FIRE-GUARD™ Combination Type AFCI Circuit Breakers

Poles	Ampere Rating	Configuration	Catalog Number
Single-Pole 10 kAIC	15	AFCI AFCI Plug-on Neutral, No Pigtail ②	CH115CAF ① CH115CAFPON
	20	AFCI AFCI Plug-on Neutral, No Pigtail ②	CH120CAF ① CH120CAFPON

- ① Clamshell packaging available with CS modification code on the end of catalog number.
- ② Requires plug-on neutral loadcenter.

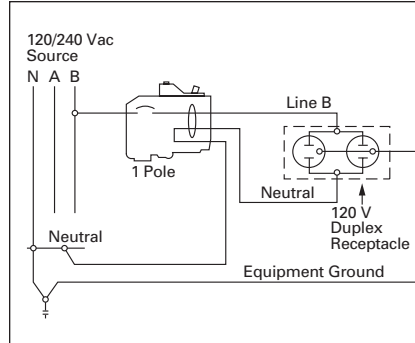

Figure 3-6. 1-Pole Single 120 Volt Load Application Sourced by 120/240 Vac

Special Application Plug-on Circuit Breakers — Ground Fault

3

Plug-on Ground Fault Circuit Breakers, Type CH 10,000 Amperes Interrupting Capacity 120 Vac and 120/240 Vac



Type CH 1-Pole

Type CH 2-Pole

Ground Fault Application Notes

Single-pole Type CHGFIs are designed for use in 2-wire, 120 Vac circuits. **Figure 3-7** shows a typical wiring configuration.

Two-pole Type CHGFIs are designed for use in 3-wire, 120/240 Vac circuits, 120 Vac multiwire circuits employing common, neutral and 2-wire, 240 Vac circuits obtained from a 120/240 Vac source.

Figure 3-8 and **Figure 3-9** illustrate typical wiring configurations for 120/240 Vac multiwire circuits.

Figure 3-10 depicts a 240 Vac, 2-wire circuit. Note the “panel neutral” conductor connects to the neutral bar, even though the neutral is not included in the load circuit. This connection is necessary to supply a 120 Vac power source to the ground fault sensing circuit.

The figures are shown with a 120/240 Vac, single-phase, 3-wire power source, but are also applicable to a 120/208 Vac, 3-phase, 4-wire power supply. For all figures, the electrical operation of the Type CHGFI is not affected by the equipment ground.

Table 3-47. Type CH Ground Fault Circuit Breakers (5 Milliampere) 3/4-Inch (19.1 mm) per Pole 120 Vac or 120/240 Vac, 10,000 AIC

Ampere Rating	Wire Size Range Cu/Al 60°C or 75°C	Catalog Number — 10,000 AIC (1 per Shelf Carton)	
		1-Pole 120 Vac Requires One 3/4-Inch (19.1 mm) Space	2-Pole 120/240 Vac Common Trip Requires Two 3/4-Inch (19.1 mm) Spaces
15	#14 – 6 ①	CH115GF	CH215GF
20		CH120GF	CH220GF
25		CH125GF	CH225GF
30		CH130GF	CH230GF
35		—	CH235GF
40		—	CH240GF
45		—	CH245GF
50		—	CH250GF
60	—	CH260GF	

① 60 ampere breaker listed for 75°C Cu wire only.

Table 3-48. Type CH Ground Fault Equipment Protectors (30 Milliampere) 3/4-Inch (19.1 mm) per Pole 120 Vac or 120/240 Vac, 10,000 AIC

Ampere Rating	Wire Size Range Cu/Al 60°C or 75°C	Catalog Number — 10,000 AIC (1 per Shelf Carton)	
		1-Pole 120 Vac Requires One 3/4-Inch (19.1 mm) Space	2-Pole 120/240 Vac Common Trip Requires Two 3/4-Inch (19.1 mm) Spaces
15	#14 – 6 ②	CH115EPD	CH215EPD
20		CH120EPD	CH220EPD
25		CH125EPD	—
30		CH130EPD	CH230EPD
40		—	CH240EPD
50		—	CH250EPD
60		—	CH260EPD

② 60 ampere breaker listed for 75°C Cu wire only.

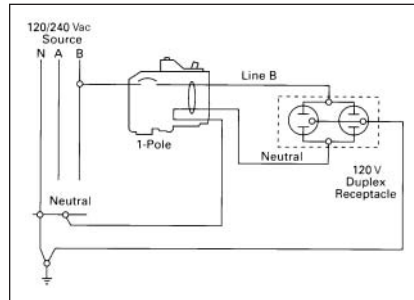

Figure 3-7. 1-Pole 120 Volt Duplex Receptacle Application

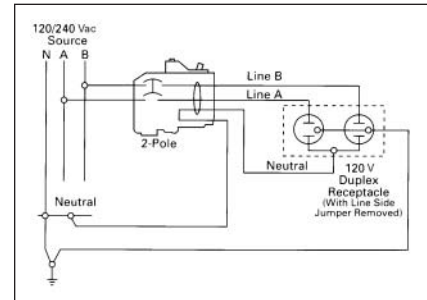

Figure 3-9. 2-Pole 120 Volt Duplex Receptacle Application

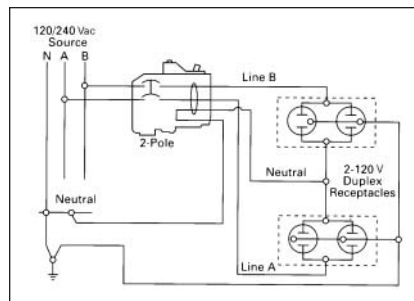

Figure 3-8. 2-Pole 120 Volt Multi-Duplex Receptacle Application

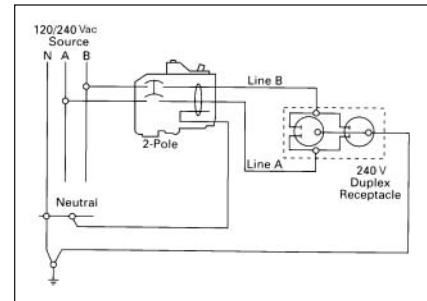
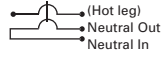
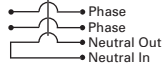

Figure 3-10. 2-Pole 240 Volt Duplex Receptacle Application

CH Switching Neutral Breakers — 10,000 Amperes Interrupting Capacity — 120 Vac and 120/240 Vac

Table 3-49. Type CH Switching Neutral Breakers, 3/4-Inch (19.1 mm) per Pole 120/240 or 240 Vac, 10,000 AIC

Used to open the neutral along power line(s) for applications of gas pumps.

Ampere Rating	Wire Size Range Cu/Al 60°C or 75°C	Catalog Number — 10,000 AIC (1 per Shelf Carton)	
		2-Pole 120 Vac Common Trip Requires Two 3/4-Inch (19.1 mm) Spaces	3-Pole 120/240 Vac Common Trip Requires Three 3/4-Inch (19.1 mm) Spaces
15 20 30 40 50	#14 – 8	 CH215SW ① CH220SW ① CH230SW ① CH240SW ① CH250SW ①	 CH315SW ② CH320SW ② CH330SW ② CH340SW ② CH350SW ②



CH220SW

- ① For circuit breakers with shunt trip, add ST suffix. Shunt trip requires one additional pole space. Obtain pricing from Page 3-37.
- ② Switching duty rated.

CH-HID Circuit Breakers — 10,000 Amperes Interrupting Capacity — 120 Vac, 120/240 and 240 Vac

Table 3-50. Type CH-HID Circuit Breakers, 3/4-Inch (19.1 mm) per Pole 120 Vac, 120/240 and 240 Vac, 10,000 AIC

Suitable for use in circuits for fluorescent and High Intensity Discharge lighting. Also suitable for HACR applications.

Ampere Rating	Wire Size Range Cu/Al 60°C or 75°C	1-Pole 120/240 Vac	2-Pole 240 Vac	3-Pole 240 Vac			
		Requires One 3/4-Inch (19.1 mm) Space	Requires Two 3/4-Inch (19.1 mm) Spaces	Requires Three 3/4-Inch (19.1 mm) Spaces			
		10 per Shelf Carton	5 per Shelf Carton	5 per Shelf Carton			
		10,000 AIC	10,000 AIC	10,000 AIC			
		Catalog Number	Price U.S. \$	Catalog Number	Price U.S. \$	Catalog Number	Price U.S. \$
15 20 30	#14 – 8	CH115HID CH120HID CH130HID		CH215HID ③ CH220HID CH230HID		CH315HID CH320HID CH330HID	

- ③ CH215HID is rated for 120/240 volts.

Non-CTL Plug-on Replacement Circuit Breakers, Type CHNT 10,000 Amperes Interrupting Capacity 120/240 Vac

Table 3-51. Type CHNT 3/4-Inch (19.1 mm) per Pole 120 Vac, Non-CTL 10,000 AIC

For use as replacement in loadcenters built prior to 1968 and within the current style 2 – 8 circuit loadcenters as indicated in the loadcenter section.

Ampere Rating	Wire Size Range Cu/Al 60°C or 75°C	1-Pole		
		Requires One 3/4-Inch (19.1 mm) Space		
		10 per Shelf Carton		
		10,000 AIC		
		Catalog Number	Price U.S. \$	
15 – 15 15 – 20 20 – 20	#14 – 8	CHNT1515 ④⑤ CHNT1520 ④⑤ CHNT2020 ④⑤		

- ④ Switching duty rated.
- ⑤ HACR rated.

CTL Plug-on Circuit Breakers, Type CHT Twin 10,000 Amperes Interrupting Capacity 120/240 Vac

Table 3-52. Type CHT Twin (CTL) 3/4-Inch (19.1 mm) per Pole 120 Vac Class CTL 10,000 AIC

All circuit breakers have rejection feature. Use only with loadcenters marked for use with CHT breakers. See photo to the right.

Ampere Rating	Wire Size Range Cu/Al 60°C or 75°C	1-Pole		
		Requires One 3/4-Inch (19.1 mm) Space		
		10 per Shelf Carton		
		10,000 AIC		
		Catalog Number	Price U.S. \$	
15 – 15 15 – 20 20 – 20	#14 – 8	CHT1515 ⑥⑦ CHT1520 ⑥⑦ CHT2020 ⑥⑦		

- ⑥ Switching duty rated.
- ⑦ HACR rated.

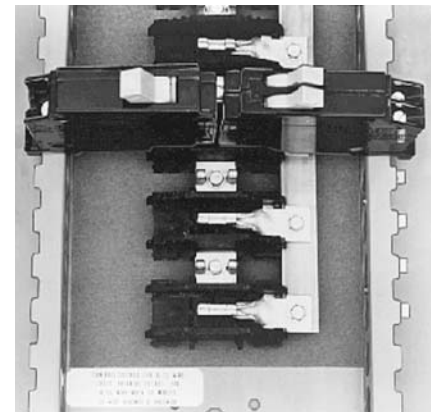



Type CH and CHT Circuit Breakers Mounted in Twin Breaker Panel

Special Application Plug-on Circuit Breakers — CHP Commercial Breakers

CHP Commercial Breakers — 10,000 Amperes Interrupting Capacity
120 Vac, 120/240 Vac and 240 Vac

Note: CHP Breakers feature on-off and trip positions for commercial applications.

Table 3-53. Type CHP Breakers, 3/4-Inch (19.1 mm) per Pole 120, 120/240 or 240 Vac, 10,000 AIC

Ampere Rating	Wire Size Range Cu/Al 60°C or 75°C	1-Pole 120/240 Vac 		2-Pole 120/240 Vac Common Trip 		3-Pole 240 Vac Common Trip 	
		Requires One 3/4-Inch (19.1 mm) Space		Requires Two 3/4-Inch (19.1 mm) Spaces		Requires Three 3/4-Inch (19.1 mm) Spaces	
		10 per Shelf Carton		5 per Shelf Carton		5 per Shelf Carton	
		10,000 AIC		10,000 AIC		10,000 AIC	
		Catalog Number	Price U.S. \$	Catalog Number	Price U.S. \$	Catalog Number	Price U.S. \$
10	(1) #14 – 8 ①	CHP110		CHP210		CHP310	
15	(2) #14 – 10 ①②	CHP115 ⑥⑦		CHP215 ⑦		CHP315 ⑦	
20	(1) #14 – 6 ③	CHP120 ⑥⑦		CHP220 ⑦		CHP320 ⑦	
25		CHP125 ⑦		CHP225 ⑦		CHP325 ⑦	
30		CHP130 ⑦		CHP230 ⑦		CHP330 ⑦	
35	#14 – 2 ① #14 – 6 ③	CHP135 ⑦		CHP235 ⑦		CHP335 ⑦	
40	#10 – 1/0 ④	CHP140 ⑦		CHP240 ⑦		CHP340 ⑦	
45	#14 – 2 ⑤	CHP145 ⑦		CHP245 ⑦		CHP345 ⑦	
50		CHP150 ⑦		CHP250 ⑦		CHP350 ⑦	
60		CHP160 ⑦		CHP260 ⑦		CHP360 ⑦	
70		CHP170		CHP270		CHP370	
80		—		CHP280		—	
90		—		CHP290		—	
100		—		CHP2100		CHP3100	
110		—		CHP2110		—	
125		—		CHP2125		—	

- ① For 1- and 2-pole breakers.
- ② Solid and stranded wire can be used together.
- ③ For 3-pole breakers.
- ④ 1-pole 60 – 70 amperes, 2-pole 80 – 125 amperes, 3-pole 40 – 100 amperes.
- ⑤ 1-pole 40 – 50 amperes, 2-pole 40 – 70 amperes.
- ⑥ Switching duty rated.
- ⑦ HACR rated.

Note: CHP Breakers offer on-off and trip positions for commercial applications.

CHP-GFCI Circuit Breakers — 10,000 Amperes Interrupting Capacity
120 Vac and 120/240 Vac

Note: CHP Breakers offer on-off and trip positions for commercial applications.

Table 3-54. Type CHP-GFCI Breakers — 5 Milliamperes — 3/4-Inch (19.1 mm) per Pole 120 V and 120/240 Vac, 10,000 AIC

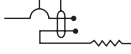
Ampere Rating	Wire Size Range Cu/Al 60°C or 75°C	1-Pole 120 Vac Requires One 3/4-Inch (19.1 mm) Space 	
		1 per Individual Carton	
		10,000 AIC	
		Catalog Number	Price U.S. \$
15	#14 – 6	CHP115GF	
20	#14 – 6	CHP120GF	
30	#14 – 6	CHP130GF	

Note: CHP Breakers offer on-off and trip positions for commercial applications.

Ground Fault Application Notes

Single-pole Type CHPGFI breakers are designed for use in 2-wire, 120 Vac circuits. **Figure 3-11** shows a typical wiring configuration.

The figure is shown with a 120/240 Vac, single-phase, 3-wire power source, but a 120/208 Vac, 3-phase, 4-wire power supply is also applicable. Electrical operation of the Type CHPGFI is not affected by the equipment ground.

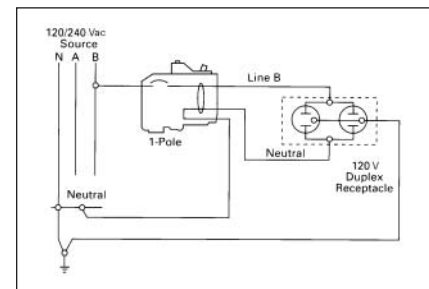

Figure 3-11. Typical 1-Pole Wiring Diagram

Discount Symbol **22CD**

CHP Neutral Switching Breakers — 10,000 Amperes Interrupting Capacity
120 Vac and 120/240 Vac

Table 3-55. Type CHP Neutral Switching Breakers, 3/4-Inch (19.1 mm) per Pole 120 or 120/240 Vac, 10,000 AIC

Used to open the neutral along power line(s) for applications of gas pumps.

Ampere Rating	Wire Size Range Cu/Al 60°C or 75°C	2-Pole 120 Vac Common Trip Requires Two 3/4-Inch (19.1 mm) Spaces		3-Pole 120/240 Vac Common Trip Requires Three 3/4-Inch (19.1 mm) Spaces	
		Catalog Number	Price U.S. \$	Catalog Number	Price U.S. \$
15	#14 – 8	CHP215SW ①		CHP315SW ①②	
20		CHP220SW ①		CHP320SW ①②	

① For circuit breakers with shunt trip, add ST suffix. Shunt trip requires one additional pole space, obtain pricing from **Page 3-37**.

② Contact your local Eaton sales office for pricing.

CH-M50 High Ambient Breaker

Table 3-56. Type CH-M50 High Ambient Breakers
3/4-Inch (19.1 mm) per Pole 120 or 120/240 Vac, 10,000 AIC

Ampere Rating	Wire Size Range Cu/Al 60°C or 75°C	1-Pole 120/240 Vac		2-Pole 120/240 Vac Common Trip Requires Two 3/4-Inch (19.1 mm) Spaces	
		Catalog Number	Price U.S. \$	Catalog Number	Price U.S. \$
15	(1) #14 – 8 (2) #14 – 10	CH115M50		CH215M50	
20		CH120M50		CH220M50	
25		CH125M50		CH225M50	
30		CH130M50		CH230M50	
35		CH135M50		CH235M50	
40		CH140M50		CH240M50	
45		CH145M50		CH245M50	
50		CH150M50		CH250M50	
60		—		CH260M50	
70		—		CH270M50	

CH-HM and CHP-HM High Magnetic Breakers

Table 3-57. Type CH-HM and CHP-HM High Magnetic Breakers
3/4-Inch (19.1 mm) per Pole 120 or 120/240 Vac, 10,000 AIC

Ampere Rating	Wire Size Range Cu/Al 60°C or 75°C	1-Pole 120/240 Vac		2-Pole 120/240 Vac Common Trip Requires Two 3/4-Inch (19.1 mm) Spaces	
		Catalog Number	Price U.S. \$	Catalog Number	Price U.S. \$
15	(1) #14 – 8 (2) #14 – 10	CH115HM		CH215HM	
20		CH120HM		CH220HM	
15	(1) #14 – 8 (2) #14 – 10	CHP115HM		CHP215HM	
20		CHP120HM		CHP220HM	

Circuit Breaker Options and Accessories

3



CH9MB270



CHLO



MCBPL



CHPL



MCBPL (Installed)



CHHT



CHPLGF



CH125RB



CHML

Table 3-58. Field Installation Kits and Parts

Description	Ordering Quantity ^①	Catalog Number	Price U.S. \$
Handle Ties ^② Handle tie bar for physically joining the handles of two adjacent 1-pole Type CH Circuit Breakers. (Molded Plastic Handle Cover)	25	CHHT	
Handle Lockoffs ^{③④} Padlockable device for locking the handle of 1-, 2- or 3-pole Type CH Circuit Breakers (Escutcheon Mounted) ^⑤	1	CHPL	
Padlockable device for locking the handle of a 1-, 2- or 3-pole Type CHGFI Circuit Breaker. (Escutcheon Mounted) ^⑤	1	CHPLGF	
Padlockable device for locking the handle of main circuit breaker Types CC and CCH into the ON or OFF position. (Screw Mounted) ^⑥	1	CCPL	
Padlockable device for locking the handle of main breaker Types BW and CSR into the ON or OFF position. (Escutcheon Mounted) ^⑤	1	MCBPL	
Handle Lockdogs ^{④⑦} Device used to secure handle in ON or OFF position for 1-pole Type CH Circuit Breakers. (Handle Mounted) ^⑧	10	CHLO	
Hold-Down Kits ^⑨ Hold-down retainer kit for 1-, 2-, 3-pole Type CH Circuit Breakers. For 6 – 24 circuit 125 ampere single- and 3-phase, 12 – 42 circuit single-phase 225 ampere and 24 – 42 circuit 3-phase 225 ampere MLO Type CH Loadcenters.	1	CH125RB	
Hold-Down Kits ^⑨ Hold-down retainer kit for 1-, 2-, 3-pole Type CH Circuit Breakers for 2 – 4 circuit MLO CH Loadcenters.	1	CH125RB24	
Mounting Bases Mounting base for 2-pole Type CH Circuit Breaker — 70 ampere maximum.	1	CH9MB270	
Main Breaker Lug Kits Types CC and CCH Main Breaker Lug Kit (2) 300 kcmil.	1	CCL300	
Type CSR Main Breaker Lug Kit (2) 300 kcmil.	1	MCBL300	
Mechanical Interlock Type CH for 2-, 3- and 4-pole breakers.	10	CHML	

- ① Must be purchased in multiples of ordering quantities indicated.
- ② Handle Ties: Typically used to join two similar independent single-pole breakers to form a 2-pole noncommon trip breaker.
- ③ Handle Lockoffs: Devices that use a padlock to lock the circuit breaker's handle in the ON or OFF position.
- ④ Requires one additional pole space.
- ⑤ Escutcheon Mounted: Device mounted semipermanently to the face of the circuit breaker and secured by the loadcenter deadfront.
- ⑥ Screw Mounted: Device permanently mounted to the face of the circuit breaker by the use of a non-removable screw.
- ⑦ Handle Lockdogs: Devices that are used to secure a circuit breaker's handle in the ON or OFF position. Handle Lockdogs are not padlockable devices.
- ⑧ Handle Mounted: Device mounted above or below handle using spring pressure.
- ⑨ Hold-Down Kits: Devices used to secure the circuit breaker to the loadcenter for back-feed main application. See NEC Article 384-16(g).

Discount Symbol 22CD

Circuit Breaker Accessories

Table 3-59. Shunt Trip Options

Description		Catalog Number Suffix Adder ①	Price U.S. \$ Adder Each
Type	Volts		
CSR	12 dc	SR12	
CSR	24 dc	SR24	
CSR	120 ac	SR01	
CH	120 ac	ST ②	
CC	12 dc	SR12	
CC	24 dc	SR24	
CC	120 ac	SR01	
CC	208 ac	SR08	
CC	240 ac	SR02	

① Add suffix indicated to end of breaker catalog number.

② Requires one additional pole space.

Table 3-60. Handle Position Changeability Chart

Handle Lockoff and Lockdog Types	To Change Handle Position from "On to "Off" or "Off" to "On" You Must...		
	Remove Padlock	Remove Device	Remove Loadcenter Deadfront
Lockoff Escutcheon Mounted	Remove	—	—
Lockoff Screw Mounted	Remove	—	—
Lockdog Handle Mounted	N/A	Remove	—

3

Technical Data and Specifications

Residential/Commercial/Unit Enclosure — Box Sizes

Table 3-61. Residential Loadcenters

Box Size	Dimensions in Inches			Dimensions in mm		
	Height	Width	Depth	Height	Width	Depth
NEMA Type 1 Indoor						
5	9.50	4.50	3.13	241.3	114.3	79.4
6	11.38	6.88	3.39	288.9	174.6	86.1
7	13.00	11.00	3.69	330.2	279.4	93.7
B	16.75	14.31	3.88	425.5	363.5	98.4
C	21.00	14.31	3.88	533.4	363.5	98.4
D	29.13	14.31	3.88	739.8	363.5	98.4
E	29.13	14.31	3.88	739.8	363.5	98.4
G	34.13	14.31	3.88	866.8	363.5	98.4
J	34.13	14.31	3.88	866.8	363.5	98.4
K	37.00	14.31	3.88	939.8	363.5	98.4
L	39.00	14.31	3.88	990.6	363.5	98.4

NEMA Type 3R Outdoor

5R	9.50	4.50	3.13	241.3	114.3	79.4
6R	11.75	6.50	4.50	298.5	165.1	114.3
7R	13.00	11.00	3.69	330.2	279.4	93.7
B	16.75	14.31	5.19	425.5	363.5	131.8
C	21.00	14.31	5.19	533.4	363.5	131.8
D	29.13	14.31	5.19	739.8	363.5	131.8
E	29.13	14.31	5.19	739.8	363.5	131.8
G	34.13	14.31	5.19	866.8	363.5	131.8
J	34.13	14.31	5.19	866.8	363.5	131.8
K	37.00	14.31	5.19	939.8	363.5	131.8
L	39.00	14.31	5.19	990.6	363.5	131.8

Table 3-62. Commercial Loadcenters

Box Size	Dimensions in Inches			Dimensions in mm		
	Height	Width	Depth	Height	Width	Depth
NEMA Type 1 Indoor						
P	54.38	21.00	6.00	1381.1	533.4	152.4
PM	62.63	21.00	6.00	1590.7	533.4	152.4

Table 3-63. Types ECB and ECC Unit Enclosures

Dimensions in Inches			Dimensions in mm		
Height	Width	Depth	Height	Width	Depth
NEMA Type 1 Indoor					
23.25	8.88	4.50	590.6	225.4	114.3
NEMA Type 3R Outdoor					
23.69	9.31	5.44	601.7	236.5	138.1

Note: Box sizes do not include covers/fronts.

Residential Loadcenter Knockout Dimensions in Inches (mm)

Residential NEMA Type 1 Indoor and NEMA Type 3R Outdoor Enclosures.

Table 3-64. Knockouts for Box Sizes 5, 6, 7, 5R, 6R, 7R

Code	Diameter in Inches				Diameter in mm			
	—	—	—	—	—	—	—	—
A	.50	—	—	—	12.7	—	—	—
B	.50	.75	—	—	12.7	19.1	—	—
C	.50	.75	1.00	—	12.7	19.1	25.4	—
D	.50	.75	1.00	1.25	12.7	19.1	25.4	31.8
E	.75	1.00	1.25	—	19.1	25.4	31.8	—
F	.75	1.00	1.25	1.50	19.1	25.4	31.8	38.1
G	1.00	1.25	1.50	—	25.4	31.8	38.1	—
H	1.00	1.25	1.50	2.00	25.4	31.8	38.1	50.8
I	1.25	1.50	2.00	—	31.8	38.1	50.8	—

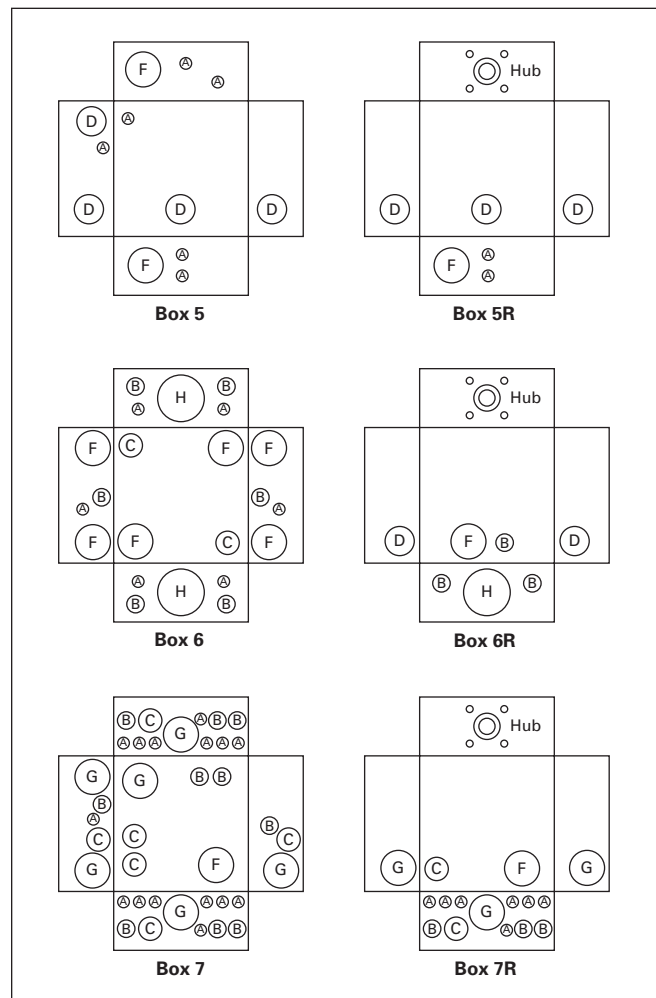

Figure 3-12. Knockout Positions

Residential and Commercial Loadcenter Knockout Dimensions in Inches (mm)

Residential NEMA Type 1 Indoor and NEMA Type 3R Outdoor Enclosures.

Table 3-65. Knockouts for Box Sizes 8, 8R, P, PM, B, C, D, E, G, J, K, L and Outdoor Boxes 12-42 CKT

Code	Diameter in Inches					Diameter in mm				
a	.75	—	—	—	—	19.1	—	—	—	—
b	.50	.75	—	—	—	12.7	19.1	—	—	—
c	.50	—	—	—	—	12.7	—	—	—	—
d	1.00	1.25	1.50	2.00	2.50	25.4	31.8	38.1	50.8	63.5
e	1.25	1.50	2.00	2.50	—	31.8	38.1	50.8	63.5	—
f	.75	1.25	1.50	2.00	—	19.1	31.8	38.1	50.8	—
g	.50	.75	1.00	—	—	12.7	19.1	25.4	—	—
h	1.50	2.00	2.50	—	—	38.1	50.8	63.5	—	—
i	.50	.75	1.00	1.25	1.50	12.7	19.1	25.4	31.8	38.1
j	1.00	1.25	1.50	—	—	25.4	31.8	38.1	—	—
k	1.25	1.50	2.00	—	—	31.8	38.1	50.8	—	—
m	.75	1.00	1.25	1.50	2.00	19.1	25.4	31.8	38.1	50.8
n	.75	1.00	1.25	1.50	—	19.1	25.4	31.8	38.1	—
p	2.00	2.50	—	—	—	50.8	63.5	—	—	—

3

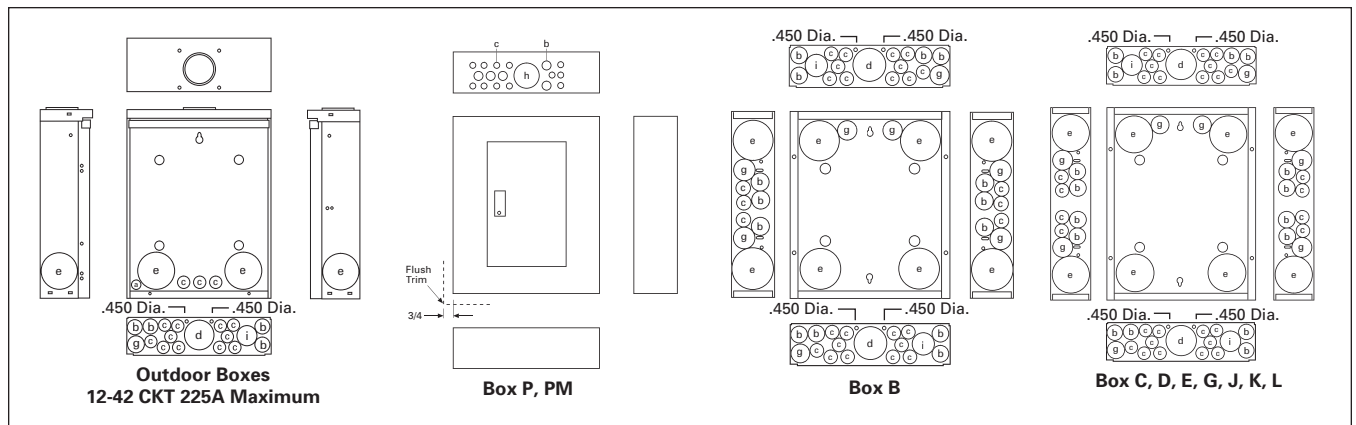

Figure 3-13. Knockout Diagram

Table 3-66. Type ECB and ECC Unit Enclosure Knockout

Code	Diameter in Inches					Diameter in mm				
NEMA Type 1 Indoor (Flush and Surface Trims)										
A	.50	—	—	—	—	12.7	—	—	—	—
B	1.25	1.50	1.75	2.00	2.50	31.8	38.1	44.5	50.8	63.5
NEMA Type 3R Outdoor										
A	.50	—	—	—	—	12.7	—	—	—	—
B	1.25	1.50	1.75	2.00	2.50	31.8	38.1	44.5	50.8	63.5

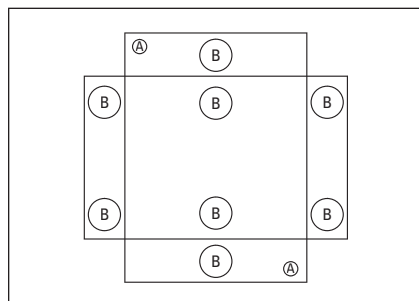

Figure 3-14. NEMA Type 1 — Indoor

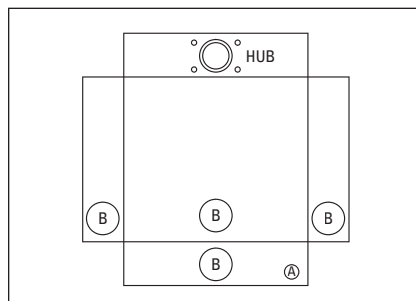

Figure 3-15. NEMA Type 3R — Outdoor

Product Description

Product Description

Loadcenters are enclosures specifically designed to house the branch circuit breakers and wiring required to distribute power to individual circuits. They contain either a main breaker when used at the service entrance point or a main lug when used as a sub-panel to add circuits to existing service. The main breaker protects the main entire panel and can be used as a service disconnect. The branch breakers protect the wires leading to individual electrical loads such as fixtures and outlets.

3

Single-Phase

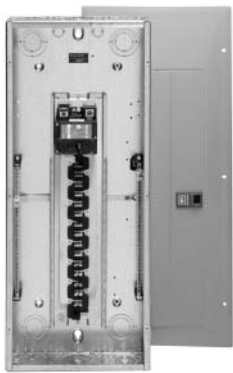

Main Circuit Breaker



Riser Panel



Single-Phase Main Lugs

Three-Phase



Main Circuit Breaker



Main Circuit Breaker Commercial



3-Phase Main Lugs

Convertible



Convertible — Outdoor

Outdoor Circuit Breaker Unit Enclosures



ECB Breaker Enclosure

Application Description

Loadcenter Construction

Cutler-Hammer Type BR loadcenters by Eaton Corporation have standard tin-plated aluminum bus with a limited availability of copper bus. The sum of the handle ratings connected to any stab is limited to 150 amperes maximum on the 100 and 125 ampere loadcenters, and 200 amperes on loadcenters with 150 ampere or higher main bus. NEMA Type 1 boxes or enclosures are manufactured from galvanized steel. Raintight boxes are manufactured from galvanized steel, then finished using an electrostatic powder coat, baked urethane paint process.

Neutrals

Eaton's Cutler-Hammer Type BR loadcenters have three types of neutrals:

Factory Bonded Split Neutral

Certain single-phase main circuit breaker panels are supplied with a factory-bonded twin neutral. When used as a sub panel, the bonding strap should be removed, and the bonding screw should be reinstalled. The bonded side is now the ground, and the un-bonded side is the neutral. When used as a service entrance panel, the unused neutral holes on either side may be used for terminating ground wires.

Insulated Split Neutral

Most single-phase panels (12 circuits and greater) are supplied with a twin neutral with an insulated cross strap. These panels are shipped in an un-bonded state. For service entrance applications, the neutral must be bonded utilizing the bonding strap supplied with the panel. For sub-feed applications, the panel may be installed as is. Separate ground bars are provided on these panels.

Single Neutral

Single-phase 2 – 8 circuit, three-phase and commercial loadcenters are supplied with a single insulated/bondable neutral. The three-phase loadcenter neutral is movable to the other side if desired. The neutral is bondable in the field by means of a bonding strap that is supplied with each loadcenter. For sub-feed applications, a separate ground bar must be used. In a service entrance application, where the neutral is bonded, unused neutral connections may be used for equipment ground protectors.

Grounds

In service entrance applications where the neutral is bonded, unused neutral holes may be used for terminating ground conductors. In sub-feed panels, the neutral must be isolated (non-bonded), and ground wires must be terminated on a separate ground bar.

The Factory Bonded Split Neutral panels have sufficient terminations for both ground and neutral conductors. The Insulated Split Neutral panels are supplied with a separate factory-installed ground bar if the catalog number contains a "G." If not, a separate ground bar should be installed. Insulated/Bondable Single Neutral panels are supplied without a ground bar (unless otherwise noted), and ground bar kits if needed must be purchased separately.

Neutral and Ground Terminals

The standard terminals on grounds and neutrals are rated to accept (3) — #14 – #10 Cu/Al or (1) — #14 – 4. For larger cables, add-on neutral lugs may be ordered from the accessories on **Page 3-64**.

Note: NEC allows only one current carrying conductor per hole on neutrals unless otherwise noted.

Bottom Fed Loadcenters

Where power cable is brought into the loadcenter from below the panel, main lug panels, and single-phase, 225 ampere and below loadcenters can be rotated 180 degrees to allow straight-in wiring of power cables to the main terminals. Because the main circuit breaker handle operates horizontally, the orientation of the main circuit breaker handle is consistent with the requirements of NEC Article 240-81.

Gutter Splicing

Loadcenters are not UL listed as wiring troughs. Therefore, gutter splicing of riser cables to tap off to the main device is not permitted. Refer to NEC Article 373-8.

Fire Rating

Due to the numerous openings in both loadcenter boxes and trims, they should not be mounted in firewalls. There is no approved method for sealing the enclosures for this application.

Date Code

The date of manufacture of each loadcenter is printed on the outside of the carton as well as inside the loadcenter. On the carton, the date code is printed on the end carton label. In the loadcenter, the date code is located on the small white label located on the right side wall (with the main device on top).

The date code is in the following format: F # # # &. The "F" is the numeric code for the Lincoln, IL plant, and the three numbers are the year and week of manufacture e.g., 023. The "&" sign at the end signifies the decade of the 2000s. Therefore, the date code F023& would indicate that the product was manufactured in the 23rd week of 2000. The 1980s are represented by a "+" sign and the 1990s are represented by a "=" at the end of the code.

Surge Protectors

The BRSURGE Surge Protector has indicating lights that indicate when the units should be replaced. The CHSA01 and CHSA03 Surge Protectors internally short, causing the circuit breaker feeding the surge protector to trip. All but the BRSURGE Surge Protector should be wired to the load side of 15 or 20 ampere feeder circuit breakers mounted adjacent to the main incoming device.

The CHSPULTRA Cutler-Hammer Home Surge Protector is an externally mounted TVSS unit that provides industrial level surge protection in a residential design.

Circuit Breaker Case Interrupting Capacity

- 10,000 AIC.
- 22,000 AIC.

Extended Residential Warranty Highlights

Note: See Cutler-Hammer Publication Number SA-365 for complete details.

- Ten-year branch breaker warranty.
- Ten-year loadcenter warranty.

Standards and Certifications

UL Listings

All Cutler-Hammer Type BR loadcenters are listed under UL File E52977 except the 2 – 8 circuit loadcenters, up through and including 125 amperes, which are listed under UL File E8741.

Features, Benefits and Functions

Features, Benefits and Functions

3

Tangential main knockout for easy installation.

Extra 1.50-inch (38.1 mm) knockout for bundling of wires.

Drywall marking on enclosure.

Twin neutral design for easier wiring and balancing of the load, located in wireway, away from circuit breakers.

Maximum wiring gutter space for ease of wiring in compliance with NEC requirements.

One piece roll formed metal backpan with circuit breaker alignment notches ensures accurately aligned breaker and bus stabs.

Six mounting holes (three top, three bottom) for ease of installation.

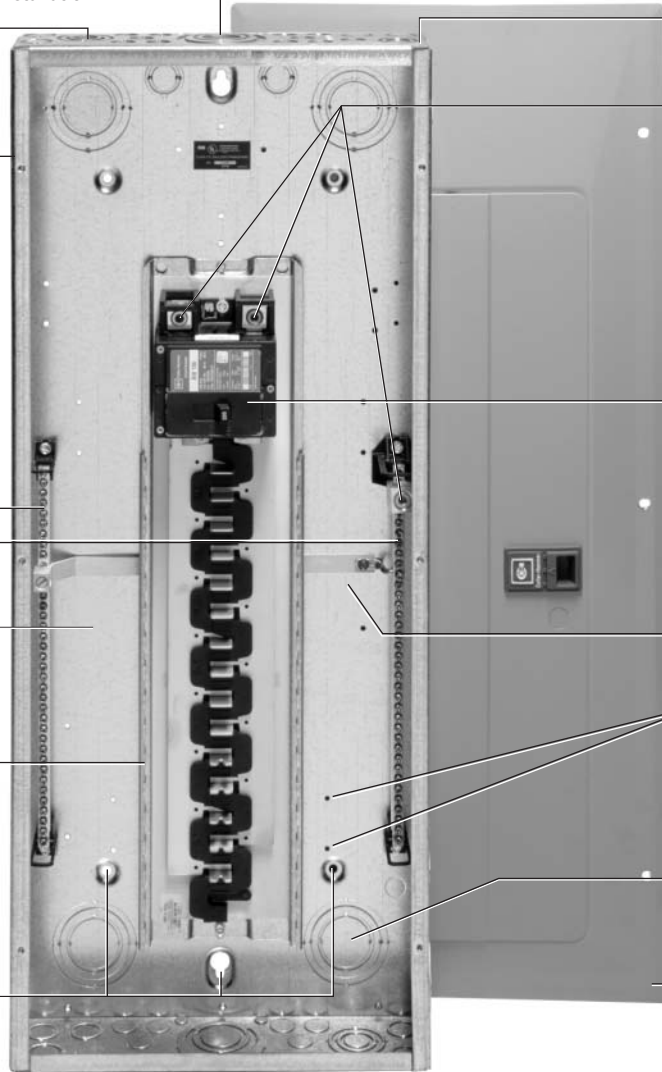

Standard 14-3/8 inches (365.1 mm) wide enclosures fit snugly between wall studs.

Same size Allen wrench can be used for phase and neutral lugs.

Commercial grade 25 kAIC rated main breaker in 150 A and above loadcenters designed for straight-in wiring that allows for top or bottom feed.

Factory pre-attached neutral bonding strap.

Predrilled mounting holes for ease of installing ground bar kits.

Maximum variety of concentric knockouts, at rear and sides.

Combination trim has sliding latch and adjustable deadfront for neat, clean appearance.

BR4040B200

Product Specifications

General

- A. The Contractor shall furnish and install deadfront loadcenters incorporating circuit breakers of the number, rating and type as specified herein and as shown on the contract drawings.
- B. The loadcenter and all components shall be designed, manufactured and tested in accordance with the latest applicable standards of UL, NEMA and NEC including:
 1. UL 67 — Standards for Panelboards.
 2. UL 50 — Standards for Cabinets and Boxes.
 3. UL 489 — Standards for Molded Case Circuit Breakers.
 4. UL 869 — Standards for Service Equipment.
 5. Federal Specification W-C 375B — Circuit Breakers.
 6. Federal Specification W-C P115b — Panel Power Distribution Type 1, Class 2.

Qualifications

- A. The manufacturer of the loadcenter shall be the manufacturer of the circuit breaker within the loadcenter.
- B. For the equipment specified herein, the manufacturer shall be ISO 9000 certified.
- C. The manufacturer of this equipment shall have produced similar electrical equipment for a minimum period of seven (7) years.

Manufacturers

- A. Cutler-Hammer business.

Ratings

- A. Loadcenters shall be rated for 120/240 Vac and shall have short circuit ratings as shown on the drawings or as herein scheduled, but not less than 10,000 amperes rms symmetrical.
- B. Circuit breakers shall be a minimum of 125 ampere frame. Circuit breakers 15 through 125 amperes trip size shall take up the same pole spacing.

- C. Loadcenters shall be labeled with a UL short circuit rating. When series combination ratings are applied with integral or remote upstream devices, a label shall be provided. Series combination ratings shall cover all trip ratings of installed frames. It shall state the conditions of the UL series ratings including:
 1. Size and type of upstream device.
 2. Branch devices that can be used.
 3. UL series short circuit rating.

Construction

- A. All interiors, with the exception of the branch circuit breakers, shall be completely factory assembled with main breakers, main lugs, or no main device.
- B. Interiors shall be designed so that circuit breakers can be replaced without disturbing adjacent units and without removing the main bus connectors and shall be designed so that circuits may be changed without machining, drilling, or tapping.
- C. Physical means shall be provided to prevent the installation of more overcurrent devices than that number for which the enclosure was designed, rated and approved. Half-size breakers shall have a UL listed rejection tab over the line terminals. Loadcenter interiors must have notched stabs to accept these rejection tab class CTL breakers, if required and approved.

Bus

- A. Bus bars for the main and cross connectors shall be [tin-plated aluminum] [copper] in accordance with Underwriters Laboratories standards. Busing shall be braced throughout to conform to industry standard practice governing short circuit stresses in loadcenters.

Note: Note to spec writer — select one (copper available in limited ratings).

- B. Neutral busing shall have a suitable lug for each outgoing feeder requiring a neutral connection of same ampacity as branch.

Wiring/Termination

- A. All wire connectors and terminals shall be of the anti-turn solderless type and shall be suitable for copper or aluminum wire of the sizes indicated. All connectors must meet the "Requirements for Wire Connectors and Soldering Lugs" as stated in UL 486B.
- B. All loadcenters where marked shall be suitable for use with 60°C or 75°C rated wire.

Circuit Breakers

- A. Circuit breakers shall be molded case type. Circuit breakers shall have four-rivet construction (GFI Type — 5 rivets). Multipole circuit breakers shall be of a stack pole design to provide electrical phase isolation.
- B. Each pole of the circuit breaker will provide inverse time delay overload and instantaneous short circuit protection by means of both thermal and magnetic sensors.
- C. The circuit breaker calibration shall not be affected by environmental changes in relative humidity. The thermal bimetal element shall be welded to the steel frame and calibration shall be set independent of the molded case by computer controlled equipment.
- D. All circuit breakers shall be operated by a toggle-type handle and multipole circuit breakers shall have an internal common trip mechanism. The circuit breakers shall incorporate trip mechanisms that are mechanically trip-free from the handle. The handle position shall provide visual trip indication.
- E. Contacts shall be of non-welding silver alloy.
- F. All circuit breakers shall have the trip rating inscribed on the handle on each circuit breaker pole. Also, unique color-coded cases that indicate the UL listed 10 kA or 22 kA interrupting ratings. Breakers shall be able to be used as main or branch disconnect devices.

Product Specifications

3

- G. Branch circuit breakers may also be used in the 1/2-inch (12.7 mm) per pole ratings that include 2-pole 1-inch (25.4 mm) wide modules and 4-pole 2-inch (50.8 mm) wide modules. 2-pole circuit breakers must incorporate a common trip mechanism. The exclusive CTL rejection tab feature shall be provided to limit the number of branch devices for a loadcenter to 42, in compliance with NEC Article 384-15.
- H. Circuit breakers shall be completely enclosed in a molded case of thermoset material. No internal aluminum parts shall be used. All internal ferrous parts shall be plated to prevent corrosion.
- I. All terminals shall be listed for use with copper or aluminum conductors. Terminals shall be of the box lug or clamp type design. The terminals shall meet UL 486B requirements and shall be suitable for use with either 60°C or 75°C wire.
- J. The calibrated bimetal assembly shall be mechanically isolated from the load terminal using a flexible braided copper shunt wire, such that movement of the terminals due to twisting and overtightening does not affect breaker calibration.
- K. Breakers shall be SWD rated and/or HACR rated as required.
- L. Arc Fault Interrupting circuit breakers, (AFI), shall be provided on all 15 and 20 ampere single-phase 120/240 Vac circuits except those indicated as remote controlled breakers. AFI breakers shall be "Classified for mitigating the effects of arcing faults," or conforming to UL Standard 1699 and as defined by Article 210-12 Section A of the 1999 NEC Code.

Surge Protection Devices

All 120/240 Vac single-phase loadcenters shall have surge protection provided by a CHSPULTRA.

- A. The CHSPULTRA, Home Surge Protector shall be supplied in its own enclosure and must be suitable for flush or surface mounting external of the loadcenter. The device shall provide surge protection for the loadcenter as well as protection for: two incoming telephone lines and one incoming coaxial cable. The surge protector shall be installed in accordance to NEC Article 280 and be listed under UL 1449, (2nd Edition), and UL 497A. The units shall be CSA certified and be tested to meet ANSI/IEEE Category B3 and C3 levels. The surge protector shall incorporate a surge plane design to facilitate a common point of grounding for all connected power, telephone, and coaxial incoming conductors. The device shall provide, as a minimum, the following protection:
1. Up to 75 kA surge current protection per phase for transients on the incoming ac line.
 2. Up to 10 kA surge protection per pair for telephone lines.
 3. Up to 5 kA line to shield (ground) protection for coaxial conductors.
- OR –
- A. The surge protection device shall be capable of plugging onto a maximum of two adjacent spaces in a single-phase loadcenter. The device shall provide, as a minimum, up to 10 kA surge current protection per phase for transients on the incoming ac line.
- B. Surge protection devices must be equipped with LEDs to indicate proper functioning of the internal electronics.

Enclosures

- A. Loadcenter shall have NEMA Type 1 general purpose or NEMA Type 3R rainproof enclosures as indicated on the drawings and shall be surface or combination flush/surface mounted except where noted.
- B. Boxes shall be made from galvanized sheet steel having multiple knockouts. Rainproof boxes shall use galvanized steel or an approved coating system which meets or exceeds standards for outdoor NEMA Type 3R enclosures. Boxes shall be of sufficient size to provide at least a minimum code gutter space on all sides.
- C. The deadfront shall have an easy adjustment feature for flush applications.
- D. Boxes shall be factory assembled into a single rigid structure.
- E. Unless otherwise noted on drawings, hinged doors covering all circuit breaker handles shall be included in all trims. Trim doors shall not uncover any live parts in making the circuit breaker handles accessible. If key locks are required, all locks shall be keyed alike.
- F. Combination trims for flush and surface panels shall be flat and shall overlap the box by at least 5/8-inch (15.9 mm) all around. Trims shall be mounted by a screwdriver without the need for special tools.

Finish

- A. Trims shall be bonderized and finished with a light gray ANSI-61 enamel. The paint finish shall be of a type to which field applied paint will adhere.

Factory Testing

- A. The standard factory tests shall be performed on the equipment provided under this section. All tests shall be in accordance with the latest version of UL and NEMA.

Product Selection

Table 3-67. BR Loadcenter Selection Chart

Service	<ul style="list-style-type: none"> ■ Single-phase, three-wire, 120/240 Vac. 	<ul style="list-style-type: none"> ■ Three-phase, four-wire, 208Y/120 Vac. ■ Three-phase, three-wire, 240 Vac delta.
Short Circuit Current Rating	<ul style="list-style-type: none"> ■ 10,000 AIC: All single- and three-phase loadcenters 70 through 225 amperes, 8 to 42 circuits. ■ 22,000 AIC: All convertible loadcenters using 125 amperes rated Type BRH main breakers or selected factory installed 125 ampere rated Type BRH main breaker. 	<ul style="list-style-type: none"> ■ 25,000 AIC: All convertible and factory installed single-phase loadcenters rated 150 and 200 amperes using Type BWH main breakers.
Main Breaker/Main Lug Loadcenters	<p>Single-Phase</p> <ul style="list-style-type: none"> ■ Main Breaker: 100, 125, 150, 200, 225, 400, 600 amperes. ■ Main Lugs: 70, 125, 150, 200, 225, 400, 600 amperes. 	<p>Three-Phase</p> <ul style="list-style-type: none"> ■ Main Breaker: 100, 125, 150, 200, 225, 400, 600 amperes. ■ Main Lugs: 100, 125, 150, 200, 225, 400, 600 amperes.
Convertible Loadcenters	<ul style="list-style-type: none"> ■ Main Breaker: Single-phase up to 200 amperes and three-phase up to 225 amperes. ■ Main Lugs: Single-phase up to 200 amperes and three-phase up to 150 amperes. 	
Branch Breakers	<ul style="list-style-type: none"> ■ Types BR, BRH, and BRH: 10 to 150 amperes. One-, two-, and three-pole. Selected amperages available in switching duty, HACR, shunt trip, and high magnetic setting. ■ Type GFCB: 15 to 50 amperes. One- and two-pole ground fault breakers. ■ Types BJ and BJH: 125 to 225 amperes Two- and three-pole. ■ Type BD Twin: 10 to 50 amperes Two of one-pole. Take one 1-inch (25.4 mm) space. 	<ul style="list-style-type: none"> ■ Type BQ and BQC Multibreaker: 15 to 30 amperes. Two of two-pole or one two-pole and two one-pole. Takes two 1-inch (25.4 mm) spaces. ■ Type BRW: 15 to 30 amperes. Two-pole water heater breakers. ■ Type BRSN: 15 to 30 amperes. Two-pole switching neutral breakers. ■ Type BR 15 to 100 amperes. Two-pole, 240 Vac delta breakers. ■ BR-ACFI arc fault circuit interrupter.
Enclosures	<ul style="list-style-type: none"> ■ NEMA Type 1 indoor. ■ NEMA Type 3R outdoor. 	<ul style="list-style-type: none"> ■ Meets or exceeds UL requirements for indoor or outdoor applications.
Loadcenter and Breaker Accessories	<ul style="list-style-type: none"> ■ Branch Circuit Breaker: Auxiliary components Hold Down Kits Handle ties Lockoffs Lockdogs ■ Complete Line of Ground Bar Kits 5, 10, 14 and 21 circuit, some with additional #2/0 lugs. Each terminal will accommodate: (3) #14 – #10 Cu/Al or (1) #14 – #4 Cu/Al. ■ Main and Sub-feed Lugs 125, 150, 225 amperes — two- and three-pole. ■ Shunt trips. 	<ul style="list-style-type: none"> ■ Surge Protection: Single-phase plug-on surge protector Single-phase bottle type surge protector Three-phase bottle type surge protector Single-phase whole home surge protector ■ Universal Rainproof Conduit Hubs <ul style="list-style-type: none"> Group One: 3/4, 1, 1-1/4, 1-1/2, 2 inches (19.1, 25.4, 31.8, 38.1, 50.8 mm) Group Two: 2, 2-1/2, 3 inches (50.8, 63.5, 76.2 mm) ■ Adapter plate.
Bussing	<ul style="list-style-type: none"> ■ Tin-plated aluminum as standard. ■ Limited copper bus panels available. 	

3

Loadcenter Catalog Numbering System

Table 3-68. Single- and Three-Phase Through 225 Amperes Catalog Numbering System

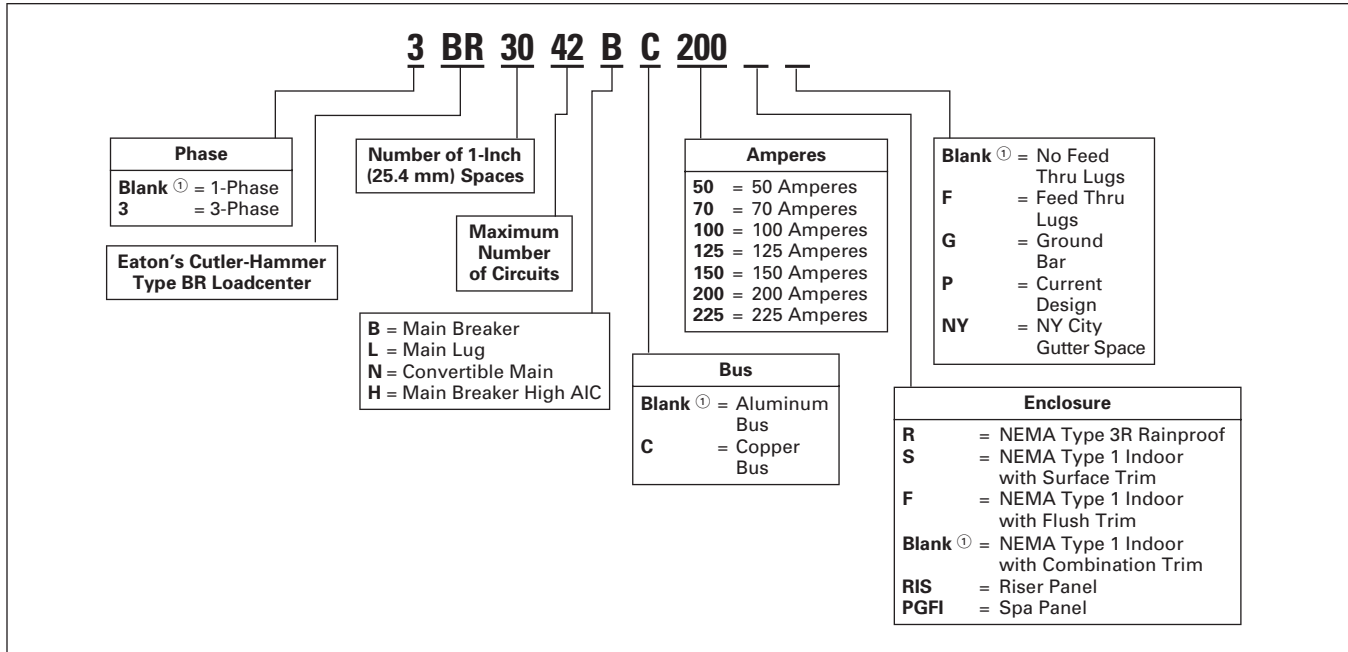

① No character space used.

Table 3-69. Single- and Three-Phase 400 Amperes Through 600 Amperes Catalog Numbering System

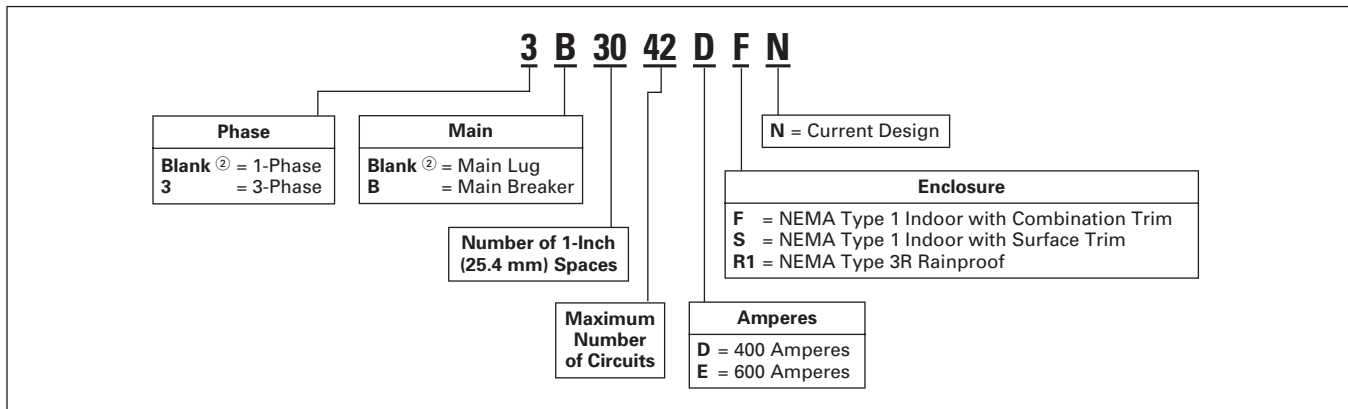

② No character space used.

Example No. 1: BR1224L125G

Single-Phase Cutler-Hammer Type BR Loadcenter Rated at 125 Amperes with Main Lugs, 12 Spaces Allowing 24 Poles, Indoor Combination Enclosure, Aluminum Bus and Ground Bar.

Example No. 2: BR24L70RP

Single-Phase Cutler-Hammer Type BR Loadcenter Rated at 70 Amperes with Main Lugs, 2 Spaces Allowing 4 Poles, Rainproof Enclosure with Aluminum Bus.

Example No. 3: 3B4242EFN

3-Phase Cutler-Hammer Type BR Loadcenter Rated at 600 Amperes with Main Breaker, 42 Spaces Allowing 42 Poles, Indoor Combination Enclosure.

Single-Phase — Main Circuit Breaker Loadcenters
10,000/25,000 Amperes Interrupting Capacity

Table 3-70. Single-Phase, 3-Wire — 120/240 Vac — Factory Bonded Split Neutral

Main Breaker Type	Main Ampere Rating	Maximum Number 1-Inch (25.4 mm)		Enclosure Type	Box Size	Wiring Diagram Figure Number	Wire Size Range Cu/Al 60°C or 75°C for Main Breaker	Loadcenter Catalog Number with Combination Cover ①	Price U.S. \$
		Space	Circuits						
BR 10 kAIC	100	20	20	Indoor	C2	68	#4 – 1/0	BR2020B100 BR1624B100	
	100	16	24	Indoor	C1	69			
BWH 25 kAIC	150	30	30	Indoor	G1	70	#2 – 300 kcmil #2 – 300 kcmil	BR3030B150 BR2040B200 BR3040B200 BR4040B200	
	200	20	40	Indoor	D1	71			
	200	30	40	Indoor	G1	72			
	200	40	40	Indoor	L1	70			

① Combination style covers may be used in surface or flush applications.

Note: All main circuit breaker loadcenters are listed for use as service entrance equipment. Loadcenters are factory bonded for service entrance applications. Remove bonding strap for separate neutral and ground bars for sub-feed applications

Table 3-71. Single-Phase 3-Wire — 120/240 Vac — Insulated/Bondable Neutral

Main Breaker Type	Main Ampere Rating	Maximum Number 1-Inch (25.4 mm)		Enclosure Type	Box Size	Wiring Diagram Figure Number	Wire Size Range Cu/Al 60°C or 75°C for Main Breaker	Loadcenter Catalog Number with Combination ② or NEMA Type 3R Cover	Price U.S. \$			
		Spaces	Circuits									
BR 10 kAIC	100	8	16	Indoor	B1	17	#4 – 1/0 ③	BR816B100 BR1020B100S11 BR1020B100F11 BR1020B100RF ④⑤ BR1212B100 BR1220B100 BR1224B100R ⑤ BR1616B100 BR1620B100 BR1624B100R ⑤ BR2024B100R ⑤				
		10	20	Indoor	A1	65						
		10	20	Indoor	A1	65						
		10	20	Outdoor	B2R	59						
		12	12	Indoor	B2	5						
		12	20	Indoor	B2	19						
		12	24	Outdoor	B2R	17						
		16	16	Indoor	C1	5						
		16	20	Indoor	C1	60						
		16	24	Outdoor	C1R	24						
		20	24	Outdoor	C3R	10						
		30	30	Indoor	⑥	⑥						
		⑥										
	BRH ⑦ 22 kAIC	125	16	24	Indoor	C1	24	#4 – 2/0	BR1624B125 BR2024B125 BR2024B125R ⑤			
20			24	Indoor	C1	10						
20			24	Outdoor	C3R	10						
BWH ⑧ 25 kAIC	150	8	16	Outdoor	C3R	18	#2 – 300 kcmil	BR816B150RF ④⑤ BR1630B150 BR2030B150 BR2030B150R ⑤ BR2040B150 BR2040B150R ⑤ BR2430B150 BR3030B150R ⑤ BR3040B150				
16		30	Indoor	C4	25							
20		30	Indoor	C4	26							
20		30	Outdoor	D1R	26							
20		40	Indoor	D1	29							
20		40	Outdoor	D1R	29							
24		30	Indoor	G1	27							
30		30	Outdoor	G1R	28							
30		40	Indoor	G1	30							
200		4	8	Outdoor	8R	46				#2 – 300 kcmil	BR48B200RF ④⑨⑩ BR816B200RF ④⑤ BR1632B200 BR2040B200R ⑤ BR2440B200 BR3040B200R ⑤ BR4040B200R ⑤	
		8	16	Outdoor	C3R	18						
		16	32	Indoor	C4	29						
		20	40	Outdoor	D1R	29						
	24	40	Indoor	G1	61							
	30	40	Outdoor	G1R	30							
225	42	42	Indoor	L2	31	#1 – 250 kcmil	BR4242B225 BR4242B225R ⑤					
	42	42	Outdoor	L2R	31							

② Combination style covers may be used in surface or flush applications.

③ Wire range size for BR1020B100SP is #6 – #1 Cu/Al.

④ Includes through-feed lugs for both phase and neutral conductors.

⑤ Rainproof panels are furnished with hub closure plates. For rainproof hubs, refer to **Page 3-63**.

⑥ See Copper Bus Offering, **Page 3-55**.

⑦ 22 kAIC series combination rating is obtained when Types BD, BR, BQ, BQC and GFCB 10 kAIC branch breakers are used in series with Type BRH main breaker.

⑧ 25 kAIC series combination rating is obtained when Types BD, BR, BQ, BQC and GFCB 10 kAIC branch circuit breakers are used in series with Type BWH main breaker.

⑨ Supplied with adapter plate to use DS Group1 hubs on **Page 3-63**. If 2.50-inch (63.5 mm) hub is needed, remove adapter and use ARP00007CH25 hub.

⑩ Neutral is bonded — suitable for service entrance only — cannot be converted for sub-feed application.

Note: All main circuit breaker loadcenters are listed for use as service entrance equipment and are shipped with neutral bonding strap preattached. The maximum rating of the panel is the main circuit breaker rating when used as service entrance equipment. Ground bar kits priced separately. See **Page 3-64**.

Box Sizes **Pages 3-77 through 3-79**
 Discount Symbol **22C**

Loadcenter Product Selection

3

Main Circuit Breaker Loadcenters
10,000/22,000/25,000 Amperes Interrupting Capacity

Table 3-72. Main Circuit Breaker Loadcenters — With Copper Bus — Single-Phase 3-Wire — 120/240 Vac — Factory Bonded Split Neutral

Main Breaker Type	Main Ampere Rating	Maximum Number 1-Inch (25.4 mm)		Enclosure Type	Box Size	Wiring Diagram Figure Number	Wire Size Range Cu/Al 60°C or 75°C for Main Breaker	Loadcenter Catalog Number with Combination Cover ①②	Price U.S. \$
		Spaces	Circuits						
BR 10 kAIC	100	20	20	Indoor	C2	68	#4 – 1/0	BR2020BC100	
		30	30	Indoor	D1	16	#4 – 1/0	BR3030BC100	
BRH 22 kAIC③	100	30	30	Indoor	D1	16	#4 – 1/0	BR3030HC100	
BWH 25 kAIC	150	30	30	Indoor	G1	70	#2 – 300 kcmil	BR3030BC150	
		20	40	Indoor	D1	71	#2 – 300 kcmil	BR2040BC200	
		30	40	Indoor	G1	72	#2 – 300 kcmil	BR3040BC200	
		40	40	Indoor	L1	70	#2 – 300 kcmil	BR4040BC200	

- ① All main circuit breaker loadcenters are listed for use as service entrance equipment and are shipped with neutral bonding strap preattached. The maximum rating of the panel is the main circuit breaker rating when used as service entrance equipment.
- ② Ground bar kits priced separately. See **Page 3-64**.
- ③ 22 kAIC series combination rating is obtained when Types BD, BR, BQ, BQC and GFCB 10 kAIC branch breakers are used in series with Type BRH main breaker

Main Circuit Breaker Loadcenters
10,000/22,000 Amperes Interrupting Capacity

Table 3-73. Single-Phase 3-Wire — 120/240 Vac — Insulated/Bondable Neutral

Main Breaker Type	Main Ampere Rating	Maximum Number 1-Inch (25.4 mm)		Enclosure Type	Box Size	Wiring Diagram Figure Number	Wire Size Range Cu/Al 60°C or 75°C for Main Breaker	Commercial Loadcenter Catalog Number ④⑤⑥			
		Spaces	Circuits					With Flush or NEMA Type 3R Cover	Price U.S. \$	With Surface Cover	Price U.S. \$
DK ⑦	300	42	42	Indoor	24	36	(2) #3/0 – 250 kcmil	BR304242F		BR304242S	
		400	42	42	Indoor	24	36	(2) #3/0 – 250 kcmil	B4242DFN		B4242DSN
				Outdoor	47	36		B4242DR1N ⑧		—	
HLD ⑨	600	42	42	Indoor	24	36	(2) #3/0 – 500 kcmil	B4242EFN		B4242ESN	

- ④ Ground bar kits priced separately. See **Page 3-64**.
- ⑤ The maximum rating of the panel is the main circuit breaker rating when used as service entrance equipment.
- ⑥ Door lock and key included with loadcenter.
- ⑦ Type DK main circuit breaker is rated 65 kAIC at 240 Vac and allows a 22 kAIC series rating on the panel when Types BR, BD and BJ branch circuit breakers are used.
- ⑧ Rainproof panels are furnished with hub closure plates. For rainproof hubs, refer to **Page 3-63**.
- ⑨ Type HLD main circuit breaker is rated 65 kAIC at 240 Vac. Type HLD circuit breaker is **not** series rated with Types BR, BD and BJ branch circuit breakers.

Box Sizes **Pages 3-77 through 3-79**
 Discount Symbol **22CD**

Loadcenter Product Selection

2 Circuits, 20 Amperes

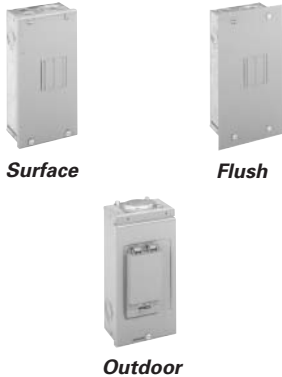

4, 6 and 8 Circuits, 125 Amperes



2 Circuits, 125 Amperes



3

Single-Phase — Main Lug Loadcenters

Table 3-74. Single-Phase 3-Wire — 120/240 Vac — Insulated/Bondable Neutral

Main Ampere Rating	Maximum Number 1-Inch (25.4 mm)		Type of Enclosure	Type of Trim	Box Size	Wiring Diagram Figure Number	Wire Size Range Cu/Al 60°C or 75°C for Main Lugs	Loadcenter Catalog Number	Price U.S. \$
	Spaces	Circuits							
70	2	4	Indoor	Surface (No Door)	5	1	#8 - #2	BR24L70SP ①② BR24L70SGP ②③ BR24L70RP ①②④ BR24L70FP ①② BR24L70FGP ②⑤	
	2	4	Indoor	Surface (No Door)	5	1			
	2	4	Outdoor	—	5R	1			
	2	4	Indoor	Flush (No Door)	5	1			
	2	4	Indoor	Flush (No Door)	5	1			
125	2	4	Indoor	Surface (No Door)	6	1	#14 - 1/0	BR24L125SP ①② BR24L125RP ①②④ BR24L125RSEP ②⑥⑦⑧ BR24L125RSE2P ②⑥⑦⑧ BR24L125FP ①②	
	2	4	Outdoor	—	6R	1			
	2	4	Outdoor	—	6R	1			
	2	4	Outdoor	—	6R	1			
	2	4	Indoor	Flush (No Door)	6	1			
	4	8	Indoor	Surface (No Door)	7	2	#14 - 1/0	BR48L125SP ①⑨ BR48L125SGP ③⑨ BR48L125RP ①④⑨ BR48L125FP ①⑨ BR48L125FDP ①⑨ BR48L125FGP ③⑨	
	4	8	Indoor	Surface (No Door)	7	2			
	4	8	Outdoor	—	7R	2			
	4	8	Indoor	Flush (No Door)	7	2			
	4	8	Indoor	Flush (With Door)	7	2			
	4	8	Indoor	Flush (No Door)	7	2			
	6	12	Indoor	Surface (No Door)	7	3	#14 - #1	BR612L125SP ①⑩ BR612L125SGP ⑩⑪ BR612L125SDP ①⑩ BR612L125SDGP ⑩⑪ BR612L125RP ①④⑩ BR612L125FP ①⑩ BR612L125FGP ⑤⑩⑪ BR612L125FDP ①⑩ BR612L125FDGP ⑤⑩⑪	
	6	12	Indoor	Surface (No Door)	7	3			
	6	12	Indoor	Surface (With Door)	7	3			
	6	12	Indoor	Surface (With Door)	7	3			
	6	12	Outdoor	—	7R	3			
	6	12	Indoor	Flush (No Door)	7	3			
	6	12	Indoor	Flush (No Door)	7	3			
	6	12	Indoor	Flush (With Door)	7	3			
	6	12	Indoor	Flush (With Door)	7	3			
	6	12	Indoor	Flush (With Door)	7	3			
	6	12	Indoor	Flush (With Door)	7	3			
	6	12	Indoor	Flush (With Door)	7	3			
	8	16	Indoor	Surface (No Door)	7	4	#14 - #1	BR816L125SP ①⑩ BR816L125SGP ⑩⑫ BR816L125SDP ①⑩ BR816L125SDGP ⑩⑫ BR816L125RP ①④⑩ BR816L125FP ①⑩ BR816L125FGP ⑤⑩⑫ BR816L125FDP ①⑩ BR816L125FDGP ⑤⑩⑫	
8	16	Indoor	Surface (No Door)	7	4				
8	16	Indoor	Surface (With Door)	7	4				
8	16	Indoor	Surface (With Door)	7	4				
8	16	Outdoor	—	7R	4				
8	16	Indoor	Flush (No Door)	7	4				
8	16	Indoor	Flush (No Door)	7	4				
8	16	Indoor	Flush With Door	7	4				
8	16	Indoor	Flush With Door	7	4				
8	16	Indoor	Flush With Door	7	4				
8	16	Indoor	Flush With Door	7	4				
8	16	Indoor	Flush With Door	7	4				

① Ground bar kits priced separately. See Page 3-64.
 – For 2/4 circuit loadcenters use GBK5 or GBK520 Ground Bar.
 – For 4/8, 6/12 and 8/16 circuit loadcenters use GBK10 Ground Bar.
 – Ground bars mount to the left side wall of the enclosure for the 4/8, 6/12 and 8/16 circuit loadcenters.

② Suitable for use as service equipment when not more than two service disconnecting mains are provided or when not used as a lighting and appliance panelboard (see Article 408.34 of the NEC).

③ Ground bar GBK5 is installed.

④ Rainproof panels are furnished with hub closure plates. For rainproof hubs, refer to Page 3-63.

⑤ CSA and UL approved.

⑥ Neutral/ground holes (6) #14 – 6 and (3) #14 – 2/0 AWG Cu/Al.

⑦ For use as service entrance applications only.

⑧ Neutral/ground holes (6) #14 – 6 and (3) #14 – 1/0 AWG Cu/Al.

⑨ Suitable for use as service equipment when not more than two service disconnecting mains are provided or when not used as six service disconnecting mains are provided and when not used as a lighting and appliance panelboard (see Article 408.34 of the NEC).

⑩ Suitable for use as service equipment when a main breaker is used or when not more than six service disconnecting mains are provided and when not used as a lighting and appliance panelboard (see Article 408.34 of the NEC).

⑪ Ground bar GBK10 is installed.

⑫ Ground bar GBK14 is installed.

Box Sizes Pages 3-77 through 3-79
 Discount Symbol 22CD

Loadcenter Product Selection

Single-Phase — Main Lug Loadcenters

Table 3-74. Single-Phase 3-Wire — 120/240 Vac — Insulated/Bondable Neutral (Continued)

Main Ampere Rating	Maximum Number 1-Inch (25.4 mm)		Enclosure Type	Box Size	Wiring Diagram Figure Number	Wire Size Range Cu/Al 60°C or 75°C for Main Lugs	Loadcenter Catalog Number with Combination or NEMA Type 3R Cover ①	Price U.S. \$
	Spaces	Circuits						
125	12	12	Indoor	B1	9	#6 – 2/0	BR1212L125 ②③④⑤ BR1224L125 ②④⑤ BR1224L125G ②④⑤⑥ BR1224L125DG ②④⑤⑦ BR1224L125R ②⑤⑧ BR1616L125 ②⑤ BR1624L125 ②④ BR1624L125G ②④⑥ BR1624L125R ②⑧ BR2020L125 ②⑤ BR2024L125 ②④ BR2024L125G ②④⑨ BR2024L125R ②⑧ BR2424L125 ②④ BR2424L125G ②④⑨	
	12	24	Indoor	B1	6			
	12	24	Indoor	B1	6			
	12	24	Indoor	B1	6			
	12	24	Outdoor	B1R	6			
	16	16	Indoor	B2	5			
	16	24	Indoor	B2	7			
	16	24	Indoor	B2	7			
	16	24	Outdoor	B2R	7			
	20	20	Indoor	C1	5			
	20	24	Indoor	C1	8			
	20	24	Indoor	C1	8			
	20	24	Outdoor	C1R	8			
	24	24	Indoor	C2	5			
24	24	Indoor	C2	5				
150	16	30	Indoor	C2	62	#1 – 300 kcmil	BR1630L150 ④⑩ BR2030L150 ④⑩	
	20	30	Indoor	C2	11			
200	8	16	Outdoor	B2R	63	#1 – 300 kcmil	BR816L200RF ⑤⑧⑩ BR1224L200 ④⑤⑩ BR1224L200R ⑤⑧⑩ BR2040L200 ④⑩ BR2040L200G ④⑨⑩ BR2040L200R ⑧⑩ BR2440L200 ④⑩ BR3040L200 ④⑩ BR3040L200G ④⑨⑩ BR3040L200R ⑧⑩ BR4040L200 ④⑩ BR4040L200G ④⑩ BR4040L200R ⑧⑩	
	12	24	Indoor	B2	12			
	12	24	Outdoor	B2R	12			
	20	40	Indoor	C2	12			
	20	40	Indoor	C2	12			
	20	40	Outdoor	C3R	12			
	24	40	Indoor	C4	64			
	30	40	Indoor	D1	15			
	30	40	Indoor	D1	15			
	30	40	Outdoor	D1R	15			
	40	40	Indoor	G1	5			
	40	40	Indoor	G1	5			
40	40	Outdoor	G1R	5				
225	42	42	Indoor	L1	20	#1 – 300 kcmil	BR4242L225 BR4242L225R ⑧	
	42	42	Outdoor	L1R	20			

- ① Ground bar kits priced separately unless otherwise noted. See Page 3-64.
- ② Has notch for BREQS125 hold-down kit.
- ③ Single, movable neutral is provided.
- ④ Combination cover style.
- ⑤ Suitable for use as service equipment when not more than six main disconnecting means are provided and when not used as a lighting and appliance panelboard (see Article 408.34 of the NEC).
- ⑥ Ground bar GBK10 installed.
- ⑦ Ground bars GBK5 and GBK520 installed.
- ⑧ Rainproof panels are furnished with hub closure plates. For rainproof hubs, refer to Page 3-63.
- ⑨ Ground bar GBK1220 installed.
- ⑩ Has notch for BRHDK125 hold-down kit.
- ⑪ Includes through-feed lugs for both phase and neutral conductors.

Single-Phase — Main Lug Loadcenters, Non-Metallic

Table 3-75. Single-Phase 3-Wire — 120/240 Vac — Insulated/Bondable Neutral

Main Ampere Rating	Maximum Number 1-Inch (25.4 mm)		Enclosure Type	Type of Trim	Box Size	Wiring Diagram Figure Number	Wire Size Range Cu/Al 60°C or 75°C for Main Lugs	Loadcenter Catalog Number	Price U.S. \$
	Spaces	Circuits							
40 ⑩	⑩	⑩	Indoor	Flush No Door	2	66	⑩	TT120FLGNM ⑩⑪ TT120SLGNM ⑩⑪	
		⑩	Indoor	Surface No Door	2	66			
60	2	4	Indoor	Flush No Door	2	1	#14 – 2	2460FNM 2460SNM 2460FGNM ⑫ 2460SGNM ⑫ 2460RNM	
		4	Indoor	Surface No Door	2	1			
		4	Indoor	Flush No Door	2	1			
		4	Indoor	Surface No Door	2	1			
		4	Outdoor	—	⑮	1			

- ⑩ Suitable for use as service equipment when not more than six main disconnecting means are provided and when not used as a lighting and appliance panelboard (see Article 408.34 of the NEC).
- ⑪ This device has no main lugs. A Type BR or BD breaker is required to be backfed to supply power to branch breakers. This device is single-phase 120 Vac only. With the use of three Type BR breakers there are two branch circuits available. With the use of three Type BD breakers there are five branch circuits available.
- ⑫ Includes GB4NM ground bar.
- ⑬ 2460 RNM uses the non-metric ACD enclosure. See ACD Section for dimensions.

Box Sizes Pages 3-77 through 3-79
Discount Symbol 22CD

Single-Phase — Main Lug Loadcenters — 400 and 600 Ampere

Table 3-76. Single-Phase 3-Wire — 120/240 Vac — Insulated/Bondable Neutral

Main Ampere Rating	Maximum Number 1-Inch (25.4 mm)		Enclosure Type	Box Size	Wiring Diagram Figure Number	Wire Size Range Cu/Al 60°C or 75°C for Main Lugs	Commercial Loadcenter Catalog Number ①②③			
	Spaces	Circuits					With Flush or NEMA Type 3R Cover	Price U.S. \$	With Surface Cover	Price U.S. \$
400	12	24	Indoor	19	44	(1) #4/0 – 750 kcmil or (2) #3/0 – 400 kcmil	—		1224DSN ⑤	
	12	24	Outdoor	42	44		1224DR1N ④⑤		—	
	24	42	Indoor	20	21		—		2442DSN	
	42	42	Indoor	22	14		4242DFN		4242DSN	
	42	42	Outdoor	46	14		4242DR1N ④		—	
600	42	42	Indoor	22	14	(2) #2 – 500 kcmil	—	4242ESN		

① Ground bar kits priced separately unless otherwise noted. See **Page 3-64**.

② Has notch for BRHDK125 hold-down kit.

③ Ground bar GBK8 installed.

④ Rainproof panels are furnished with hub closure plates. For rainproof hubs, refer to **Page 3-63**.

⑤ Suitable for use as service equipment when not more than six main disconnecting means are provided and when not used as a lighting and appliance panelboard (see Article 408.34 of the NEC).

Table 3-77. Single-Phase 3-Wire — 120/240 Vac — Single Neutral with Copper Bus

Main Ampere Rating	Maximum Number 1-Inch (25.4 mm)		Enclosure Type	Type of Trim	Box Size	Wiring Diagram Figure Number	Wire Size Range Cu/Al 60°C or 75°C for Main Lugs	Loadcenter Catalog Number	Price U.S. \$
	Spaces	Circuits							
125	8	16	Indoor	Surface w/door	7	7	#14 – 1	BR816LC125SDP BR816LC125FDP	
	8	16	Indoor	Flush w/door	7	7			

Loadcenter Product Selection

3-Phase — Main Circuit Breaker Loadcenters
10,000 Amperes Interrupting Capacity

Table 3-78. 3-Phase 4-Wire — 208Y/120 Vac or 240 Vac Insulated/Bondable Neutral

Main Breaker Type	Main Ampere Rating	Maximum Number 1-Inch (25.4 mm)		Enclosure Type	Box Size	Wiring Diagram Figure Number	Wire Size Range Cu/Al 60°C or 75°C for Main Breaker	Loadcenter Catalog Number ^{①②} (With Combination or NEMA Type 3R Cover)	Price U.S. \$	
		Spaces	Circuits							
BR 10 kAIC	100	12	24	Indoor	C1	65	#4 – 1/0	3BR1224B100 3BR1224B100R ^③		
		12	24	Outdoor	C1R	65				
CC 10 kAIC	150	30	42	Indoor	L1	41	#1 – 3/0	3BR3042B150 3BR3042B150R ^③		
		30	42	Outdoor	L1R	41				
	200	30	42	42	Indoor	L1	41	#1 – 250 kcmil	3BR3042B200 3BR3042B200R ^③ 3BR4242B200 3BR4242B200R ^③	
			30	42	Outdoor	L1R	41			
		42	42	Indoor	L2	43				
		42	42	Outdoor	L2R	43				
	225	42	42	42	Indoor	L2	43	#1 – 300 kcmil	3BR4242B225 3BR4242B225R ^③	
			42	42	Outdoor	L2R	43			

- ① All main circuit breaker loadcenters are listed for use as service entrance equipment and are shipped with a neutral bonding strap pre-attached (commercial loadcenters do not have a pre-attached bonding strip). The maximum main rating of the panel is the main circuit breaker rating when used as service entrance equipment.
- ② Ground bar kits priced separately. See **Page 3-64**.
- ③ Rainproof loadcenters are furnished with hub closure plates. For rainproof hubs, refer to **Page 3-63**.

3-Phase — Main Circuit Breaker Loadcenters
22,000/65,000 Amperes Interrupting Capacity

Table 3-79. 3-Phase, 4-Wire — 208Y/120 Vac or 240 Vac Insulated/Bondable Neutral

Main Breaker Type	Main Ampere Rating	Maximum Number 1-Inch (25.4 mm)		Enclosure Type	Box Size	Wiring Diagram Figure Number	Wire Size Range Cu/Al 60°C or 75°C for Main Breaker	Commercial Loadcenter Catalog Number ^{④⑤⑥} (With Combination or NEMA Type 3R Cover)	Price U.S. \$
		Spaces	Circuits						
DK ^⑦ 22 kAIC	400	42	42	Indoor	24	42	(2) #3/0 – 250 kcmil	3B4242DFN 3B4242DR1N ^⑧	
		42	42	Outdoor	47	42			
LD ^⑨	600	42	42	Indoor	24	42	(2) #3/0 – 500 kcmil	3B4242EFN	

- ④ All main circuit breaker loadcenters are listed for use as service entrance equipment and are shipped with a neutral bonding strap pre-attached (commercial loadcenters do not have a pre-attached bonding strip). The maximum main rating of the panel is the main circuit breaker rating when used as service entrance equipment.
- ⑤ Ground bar kits priced separately. See **Page 3-64**.
- ⑥ Door lock and key included with loadcenter.
- ⑦ Type DK main circuit breaker is rated 65 kAIC at 240 Vac and allows a 22 kAIC series rating on the loadcenter when Types BR, BD and BJ branch circuit breakers are used.
- ⑧ Rainproof loadcenters are furnished with hub closure plates. For rainproof hubs, refer to **Page 3-63**.
- ⑨ The LD main circuit breaker is rated 65 kAIC at 240 Vac. Type LD circuit breaker is **not** series rated with Types BR, BD and BJ branch circuit breakers.

3-Phase — High Interrupting Rated Main Circuit Breaker Loadcenters
22,000/100,000 Amperes Interrupting Capacity

Table 3-80. 3-Phase 4-Wire — 208Y/120 Vac or 240 Vac Insulated/Bondable Neutral

Main Breaker Type	Main Ampere Rating	Maximum Number 1-Inch (25.4 mm)		Enclosure Type	Box Size	Wire Size Range Cu/Al 60°C or 75°C for Main Breaker	Loadcenter Catalog Number ^{⑩⑪}	
		Spaces	Poles				with Combination Cover	with Surface Cover
BRH 22 kAIC ^⑫	100	12	24	Indoor	C1	#4 – 1/0	3BR1224H100	3BR1224H100S
CHH 100 kAIC ^⑬	150	30	42	Indoor	L1	#1 – 250 kcmil	3BR3042H150	3BR3042H150S
CHH 100 kAIC ^⑬	200	30	42	Indoor	L1	#1 – 250 kcmil	3BR3042H200	3BR3042H200S
		42	42	Indoor	L2		3BR4242H200	3BR4242H200S

- ⑩ All main circuit breaker loadcenters are listed for use as service entrance equipment and are shipped with a neutral bonding strap pre-attached.
- ⑪ Ground bar kits priced separately.
- ⑫ 22,000 AIC series combination rating is obtained when Types BD, BR, BQ, BQC and GFGB branch breakers are used with BRH main.
- ⑬ 100,000 AIC series combination rating is obtained when Types BD, BR, BQ, BQC and GFGB branch breakers are used with CHH main.

Box Sizes **Pages 3-77** through **3-79**
Discount Symbol **22CD**

Loadcenter Product Selection

3

3-Phase — Main Lug Loadcenters

Table 3-81. 3-Phase 4-Wire — 208Y/120 Vac or 240 Vac Insulated/Bondable Neutral

Main Ampere Rating	Maximum Number 1-Inch (25.4 mm)		Enclosure Type	Box Size	Wiring Diagram Figure Number	Wire Size Range Cu/Al 60°C or 75°C for Main Lugs	Loadcenter Catalog Number ^① (With Combination or NEMA Type 3R Cover)	Price U.S. \$
	Spaces	Circuits						
100	3	3	Indoor	9	32	#14 – 1/0	3BR3L100S ^② 3BR3L100R ^③	
	3	3	Outdoor	9R	32			
125	12	24	Indoor	C1	35	#6 – 2/0	3BR1224L125 ^{④⑤} 3BR1224L125R ^{③④⑤}	
	12	24	Outdoor	C1R	35			
150	24	42	Indoor	D1	34	#1 – 300 kcmil	3BR2442L150 3BR2442L150R ^③	
	24	42	Outdoor	D1R	34			
200	12	24	Indoor	C4	35	#1 – 300 kcmil	3BR1224L200 ^⑤ 3BR1224L200R ^{③⑤} 3BR3042L200 3BR3042L200R ^③ 3BR4242L200 3BR4242L200R ^③	
	12	24	Outdoor	C3R	35			
	30	42	Indoor	G1	33			
	30	42	Outdoor	G1R	33			
	42	42	Indoor	L1	37			
	42	42	Outdoor	L1R	37			
225	42	42	Indoor	L1	37	#1 – 300 kcmil	3BR4242L225 3BR4242L225R ^③	
	42	42	Outdoor	L1R	37			

- ① Ground bar kits priced separately. See **Page 3-64**.
- ② Surface cover only.
- ③ Rainproof loadcenters are furnished with hub closure plates. For rainproof hubs, refer to **Page 3-63**.
- ④ Has notch for BREQS125 hold-down kit.
- ⑤ Suitable for use as service equipment when not more than six main disconnecting means are provided and when not used as a lighting and appliance panelboard (see Article 408.34 of the NEC).
- ⑥ Door lock and key included with loadcenter.

3-Phase — Main Lug Loadcenters

Table 3-82. 3-Phase, 4-Wire — 208Y/120 Vac or 240 Vac Insulated/Bondable Neutral

Main Ampere Rating	Maximum Number 1-Inch (25.4 mm)		Enclosure Type	Box Size	Wiring Diagram Figure Number	Wire Size Range Cu/Al 60°C or 75°C for Main Lugs	Commercial Loadcenter Catalog Number ^⑦			
	Spaces	Circuits					With Flush or NEMA Type 3R Cover	Price U.S. \$	With Surface Cover	Price U.S. \$
400	18	36	Indoor	19	40	(1) 250 – 750 kcmil or (2) #3/0 – 250 kcmil	—		—	
	18	36	Outdoor	43	40		—		—	
	24	42	Indoor	19	38		—		—	
	42	42	Indoor	22	39		34242DFN			34242DSN
	42	42	Outdoor	46	39		34242DR1N ^⑧			—
600	42	42	Indoor	22	39	(2) #2 – 500 kcmil	—			34242ESN

- ⑦ Door lock and key included with loadcenter.
- ⑧ Rainproof loadcenters are furnished with hub closure plates. For rainproof hubs, refer to **Page 3-63**.

Box Sizes **Pages 3-77 through 3-79**
 Discount Symbol **22CD**

Loadcenter Product Selection

Convertible Loadcenters MCB or MLO — Base Units and Main Devices
10,000/22,000/25,000 Amperes Interrupting Capacity
Complete Assembly Consists of: Loadcenter and Either Main Breaker Kit or Main Lug Kit

Note: Interrupting rating depends on main circuit breaker selected.

3

Table 3-83. Base Units — Single-Phase 3-Wire — 120/240 Vac — Insulated/Bondable Neutral

Main Ampere Rating ^①	Maximum Number 1-Inch (25.4 mm)		Enclosure Type	Box Size	Wiring Diagram Figure Number	Wire Size Range Cu/Al 60°C or 75°C for Main	Loadcenter Catalog Number With Combination or NEMA Type 3R Cover ^{②③}	Price U.S. \$	
	Spaces	Circuits							
125 ^④	12	24	Indoor	B2	49	See main breaker and main lug kit tables next page.	BR1224N125 ^{⑤⑥} BR1224N125R ^{⑤⑥⑦} BR1624N125 ^⑤ BR1624N125R ^{⑤⑦} BR2024N125 ^⑤ BR2024N125R ^{⑤⑦}		
	12	24	Outdoor	B2R	49				
	16	24	Indoor	C1	45				
	16	24	Outdoor	C1R	45				
	20	24	Indoor	C2	50				
	20	24	Outdoor	C3R	50				
200 ^⑧	8	16	Outdoor	C3R	52		See main breaker and main lug kit tables next page.	BR816N200RF ^{⑦⑨⑩} BR1224N200 ^⑩ BR1224N200R ^{⑦⑩} BR1632N200 ^⑩ BR2040N200 ^⑩ BR2040N200G ^⑪ BR2040N200R ^{⑦⑩} BR2040N200RG ^⑪ BR2440N200 ^{⑦⑩} BR3040N200 ^⑩ BR3040N200G ^⑪ BR3040N200R ^{⑦⑩} BR3040N200RG ^⑪ BR4040N200 ^⑩ BR4040N200G ^⑪ BR4040N200R ^{⑦⑩} BR4040N200RG ^⑪	
	12	24	Indoor	C4	13				
	12	24	Outdoor	C3R	13				
	16	32	Indoor	C4	13				
	20	40	Indoor	D1	13				
	20	40	Indoor	D1	13				
	20	40	Outdoor	D1R	13				
	20	40	Outdoor	D1R	13				
	24	40	Indoor	G1	61				
	30	40	Indoor	G1	53				
	30	40	Indoor	G1	53				
	30	40	Outdoor	G1R	53				
	30	40	Outdoor	G1R	53				
	40	40	Indoor	L1	47				
	40	40	Indoor	L1	47				
	40	40	Outdoor	L1R	47				
	40	40	Outdoor	L1R	47				

- ① The maximum rating of the loadcenter is the main circuit breaker rating when used as service entrance equipment.
- ② 100, 125 and 200 ampere Convertible base unit catalog numbers include interior, box and cover only. Main devices and accessories must be ordered separately for field installation. All Convertible base units are listed as suitable for use as service entrance equipment when used per Article 384 of the NEC.
- ③ Ground bar kits priced separately except as noted, refer to **Page 3-64**.
- ④ For main breaker, use Type BR. For main lug use Type BRSF.
- ⑤ BREQS125 hold-down screw comes with loadcenter for back-fed Types BR and BRH main circuit breakers.
- ⑥ Convertible to maximum of 100 ampere main circuit breaker and 125 ampere main lug.
- ⑦ Rainproof loadcenters are furnished with hub closure plates. For rainproof hubs, refer to **Page 3-63**.
- ⑧ For main breaker, use Type BW. For main lug use Type BRL.
- ⑨ Includes through-feed lugs for both phase and neutral conductors.
- ⑩ No hold-down provisions for back-fed Types BR and BRH main circuit breakers.
- ⑪ Includes GBK2120 ground bar.

Table 3-84. Base Units — 3-Phase 4-Wire — 208Y/120 Vac or 240 Vac Insulated/Bondable Neutral

Main Ampere Rating ^②	Maximum Number 1-Inch (25.4 mm)		Enclosure Type	Box Size	Wiring Diagram Figure Number	Wire Size Range Cu/Al 60°C or 75°C for Main	Loadcenter Catalog Number ^{③④} (With Combination or NEMA Type 3R Cover)	Price U.S. \$
	Spaces	Circuits						
100 ^⑤	30	30	Indoor	D1	48	See main breaker and main lug kit tables next page.	3BR3030N100 ^⑥ 3BR3030N100R ^{⑥⑦}	
	30	30	Outdoor	D1R	48			
125 ^⑤	12	24	Indoor	C1	51		3BR1224N125 ^{⑥⑦⑧} 3BR1224N125R ^{⑥⑦⑧⑨}	
	12	24	Outdoor	C1R	51			

- ② The maximum rating of the loadcenter is the main circuit breaker rating when used as service entrance equipment.
- ③ 100, 125 and 200 ampere Convertible base unit catalog numbers include interior, box and cover only. Main devices and accessories must be ordered separately for field installation. All Convertible base units are listed as suitable for use as service entrance equipment when used per Article 384 of the NEC.
- ④ Ground bar kits priced separately, refer to **Page 3-64**.
- ⑤ For main breaker, use Type BR. For main lug use Type BRSF.
- ⑥ BREQS125 hold-down screw comes with loadcenter for back-fed Types BR and BRH main circuit breakers.
- ⑦ Rainproof loadcenters are furnished with hub closure plates. For rainproof hubs, refer to **Page 3-63**.
- ⑧ Convertible to maximum of 100 ampere main circuit breaker and 125 ampere main lug.
- ⑨ Suitable for use as service equipment when not more than six main disconnecting means are provided and when not used as a lighting and appliance panelboard (see Article 408.34 of the NEC).

Box Sizes **Pages 3-77 through 3-79**
Discount Symbol **22CD**

Convertible Loadcenters — With Copper Bus 10,000/22,000/25,000 Amperes Interrupting Capacity

Table 3-85. Convertible — Single-Phase 3-Wire — 120/240 Vac — Insulated/Bondable Neutral

Main Ampere Rating	Maximum Number 1-Inch (25.4 mm)		Enclosure Type	Box Size	Wiring Diagram Figure Number	Wire Size Range Cu/Al 60°C or 75°C for Main	Loadcenter Catalog Number with Combination or NEMA Type 3R Cover ①②③	Price U.S. \$	
	Spaces	Circuits							
125 10/22 kAIC ④⑤	12	24	Indoor	B2	49	See main breaker and main lug kit tables on Page 3-55.	BR1224NC125 ⑥⑦ BR1224NC125R ⑥⑦⑧ BR2024NC125 ⑥ BR2024NC125R ⑥⑧		
	12	24	Outdoor	B2R	49				
	20	24	Indoor	C2	50				
	20	24	Outdoor	C3R	50				
200 10/25 kAIC ④⑨	20	40	Indoor	D1	13		BR2040NC200 BR2040NC200R ⑥ BR3040NC200 BR3040NC200R ⑥ BR4040NC200 BR4040NC200R ⑥		
	20	40	Outdoor	D1R	13				
	30	40	Indoor	G1	53				
	30	40	Outdoor	G1R	53				
	40	40	Indoor	L1	47				
	40	40	Outdoor	L1R	47				

- ① All main circuit breaker loadcenters are listed for use as service entrance equipment and are shipped with a neutral bonding strap preattached. The maximum main rating of the loadcenter is the main breaker rating when used as service entrance equipment.
- ② Ground bar kits priced separately. See Page 3-64.
- ③ 100, 125 and 200 ampere Convertible base unit catalog numbers include interior, box and cover only. Main devices must be ordered separately from Page 3-55. Accessories must also be ordered separately for field installation. All Convertible base units are listed as suitable for use as service entrance equipment when used per Article 384 of the NEC.
- ④ Interrupting rating depends on main circuit breaker selected. See Page 3-55 for mains.
- ⑤ For main breaker, use Type BW. For main lug use Type BRL.
- ⑥ Hold-down screw BREQS125 comes with loadcenter for back-fed Types BR and BRH main circuit breakers.
- ⑦ Suitable for use as service equipment when not more than six main disconnecting means are provided and when not used as a lighting and appliance panelboard (see Article 408.34 of the NEC).
- ⑧ Rainproof loadcenters are furnished with hub closure plates. For rainproof hubs, refer to Page 3-63.
- ⑨ For main breaker, use Type BR. For main lug use Type BRSF.

Convertible Loadcenters MCB or MLO — Base Units and Main Devices

10,000/22,000/25,000 Amperes Interrupting Capacity

Complete Assembly Consists of: Loadcenter and Either Main Breaker Kit or Main Lug Kit

Note: Interrupting rating depends on main circuit breaker selected.

Table 3-86. Main Devices
2- and 3-Pole Main Circuit Breakers
120/240 Vac or 208Y/120 Vac or 240 Vac

Ampere Rating	Wire Size Range Cu/Al 60°C or 75°C for Main Breaker	10,000 AIC		22,000/25,000 AIC	
		Catalog Number	Price U.S. \$	Catalog Number ⑩	Price U.S. \$
2-Pole					
100	#4 – 1/0	BR2100		BRH2100	
110	#4 – 1/0	BR2110		BRH2110	
125	#4 – 2/0	BR2125		BRH2125	
125	#2 – 300 kcmil	BW2125		BWH2125	
150	#2 – 300 kcmil	BW2150		BWH2150	
175	#2 – 300 kcmil	BW2175		BWH2175	
200	#2 – 300 kcmil	BW2200		BWH2200	
3-Pole					
100	#1	BR3100		BRH3100	

⑩ Series combination rating with Types BD, BR, BQ, BQC and GFCB is 22,000 AIC with BRH main and 25,000 AIC with BWH main.

Table 3-87. Main Devices
2- and 3-Pole Main Lug Kits
120/240 Vac or 208Y/120 Vac or 240 Vac

Ampere Rating	Wire Size Range Cu/Al 60°C or 75°C for Main Lugs	Catalog Number	Price U.S. \$
2-Pole			
125	#6 – 2/0	BRSF125	
150	#1 – 300 kcmil	BRL200	
175	#1 – 300 kcmil	BRL200	
200	#1 – 300 kcmil	BRL200	
3-Pole			
150	#6 – 3/0	3BRSF150	

Main Circuit Breaker with Accessory

Example: BW22005R01
(Put description with catalog number on order. See Page 3-76.)

Spa Panels

Table 3-88. Spa Panel

Main Ampere Rating	Maximum Number 1-Inch (25.4 mm)		Enclosure Type	Wiring Diagram Figure Number	Box Size	Wire Size Range Cu/Al 60°C or 75°C for Main Lugs	Catalog Number	Price U.S. \$
	Space	Poles						
40	—	—	Outdoor	—	5R	#8 – #2	BR40SPA ⑪	
50	—	—	Outdoor	—	5R	#8 – #2	BR50SPA ⑫	

- ⑪ Includes a GFCB240 breaker, factory installed.
- ⑫ Includes a GFCB250 breaker, factory installed.

Box Sizes Pages 3-77 through 3-79
Discount Symbol 22CD

Loadcenter Product Selection

Commercial Loadcenters — Indoor Enclosures
Main Circuit Breaker, Main Lug and Convertible, New York City Approved
Single-Phase and Three-Phase

Table 3-89. Single-Phase Main Circuit Breaker — Factory Installed

Main Breaker Type	Main Ampere Rating	Maximum Number 1-Inch (25.4 mm)		Enclosure Type	Box Size	Wiring Diagram Figure Number	Wire Size Range Cu/Al 60°C or 75°C for Main Breaker	Loadcenter Catalog Number	Price U.S. \$	Loadcenter Cover Catalog Number		Price U.S. \$
		Spaces	Circuits							Flush	Surface	

Single-Phase 3-Wire — 120/240 Vac Insulated/Bondable Neutral

CC 10 kAIC	200	42	42	Indoor	A	56	#1 – 300 kcmil	BR4242B200NY ①		3BR42FTNY	3BR42STNY	
------------	-----	----	----	--------	---	----	----------------	----------------	--	-----------	-----------	--

① Approved for 150 ampere and up for residential services in New York City.

Table 3-90. Single-Phase Main Lugs — Factory Installed

Main Lug Ampere Rating	Maximum Number 1-Inch (25.4 mm)		Enclosure Type	Box Size	Wiring Diagram Figure Number	Wire Size Range Cu/Al 60°C or 75°C for Main Lugs	Loadcenter Catalog Number	Price U.S. \$	Loadcenter Cover Catalog Number		Price U.S. \$
	Spaces	Circuits							Flush	Surface	

Single-Phase 3-Wire — 120/240 Vac Insulated/Bondable Neutral

225	42	42	Indoor	A	55	#1 – 300 kcmil	BR4242L225NY ②		3BR42FTNY	3BR42STNY	
-----	----	----	--------	---	----	----------------	----------------	--	-----------	-----------	--

② Approved for 150 ampere and up for residential services in New York City.

Table 3-91. Three-Phase Convertible Loadcenters

Main Ampere Rating	Maximum Number 1-Inch (25.4 mm)		Enclosure Type	Box Size	Wiring Diagram Figure Number	Wire Size Range Cu/Al 60°C or 75°C for Main Breaker	Loadcenter Catalog Number	Price U.S. \$	Loadcenter Cover Catalog Number		Price U.S. \$
	Spaces	Circuits							Flush	Surface	

3-Phase 4-Wire — 120/240 Vac Insulated/Bondable Neutral

225	42	42	Indoor	B	56	#1 – 300 kcmil	3BR4242N225NY ③④		3BR42FTNY	3BR42STNY	
-----	----	----	--------	---	----	----------------	------------------	--	-----------	-----------	--

③ Approved for 150 ampere and up for residential services in New York City.

④ Order main device from **Table 3-92** and **Table 3-93** below.

Table 3-92. Three-Phase Main Breaker Kits

Ampere Rating	Wire Size Range Cu/Al 60°C or 75°C	Main Breaker Kit 10 kAIC	Price U.S. \$
150	#4 – 4/0	CC3150N	
175	#2/0 – 300 kcmil	CC3175N	
200		CC3200N	
225		CC3225N	

Table 3-93. Three-Phase Main Lugs Kit

Ampere Rating	Wire Size Range Cu/Al 60°C or 75°C	Main Lugs Kit	Price U.S. \$
225	#2/0 – 300 kcmil	3BRL225	

Single-Phase and 3-Phase Circuit Breaker Unit Enclosures — 10,000/25,000 Amperes Interrupting Capacity



Circuit Breaker Unit Enclosures



BWH2200

3

Table 3-94. Type ECB Circuit Breaker Unit Enclosure — Order Type BW and BWH Circuit Breaker Separately — Unit Enclosure Includes Lug Tree Kit

Main Ampere Rating	Unit Enclosure Type	Mounting	Type of Circuit Breaker	Wire Size Range Cu/AI 60°C or 75°C	Catalog Number	Price U.S. \$
Single-Phase 3-Wire — 240 Vac Maximum						
225	Indoor	Flush	BW, BWH	①	ECB225F ②③④	
225	Indoor	Surface	BW, BWH	①	ECB225S ②③④	
225	Outdoor	—	BW, BWH	①	ECB225R ②③④⑤	

- ① Wire size is determined by the circuit breaker installed in enclosure. Maximum wire size and ampere rating is determined by **Table 3-96**.
- ② Order circuit breaker separately.
- ③ One ground lug accepting (1) #14 – #2 is factory installed. Also, there are pre-drilled holes to accept a GBK5 ground bar.
- ④ Approved for service entrance.
- ⑤ Rainproof panels are furnished with hub closure plates. For rainproof hubs, refer to **Page 3-63**.

Table 3-95. Types BW and BWH Circuit Breakers 120/240 Vac — 25,000 AIC for Use in Type ECB Unit Enclosures

Ampere Rating	2-Pole Breakers 10,000 AIC		Wire Size Range Cu/AI 60°C or 75°C for Line Terminals	2-Pole Breakers 25,000 AIC	
	Catalog Number	Price U.S. \$		Catalog Number	Price U.S. \$
125	BW2125		#2 – 300 kcmil	BWH2125	
150	BW2150			BWH2150	
175	BW2175			BWH2175	
200	BW2200			BWH2200	
225	BW2225			BWH2225	

Table 3-96. Wire/Application Chart

Wire/Application	Maximum Wire Size	Maximum Ampere Rating
Aluminum — Standard	250 kcmil	200
Aluminum — Service Entrance	250 kcmil	225
Copper — Standard and Service Entrance	250 kcmil	225

Table 3-97. BW/BWH Lug Tree Kit for Replacement Purposes Only for Use in Type ECB Unit Enclosures

Ampere Rating	Description	Wire Size Range Cu/AI 60°C or 75°C for Line Terminals	Catalog Number	Price U.S. \$
225	For use on 125, 150, 175, 200 and 225 Ampere BW and BWH Breakers	#2 – 300 kcmil	MCBK225	

Table 3-98. Shunt Trips, Auxiliary and Alarm Contacts

Description	Catalog Number Suffix Adder ⑥	Price U.S. \$ ⑦ Adder Each
Shunt Trip for Types BW/BWH		
12 Volts	SR12	
24 Volts	SR24	
120 Volts	SR01	
Auxiliary Contact for Types BW/BWH		
(1) NO and (1) NC	AL1	
(2) NO and (2) NC	AL2	
Alarm Contacts for Types BW/BWH		
Types BW/BWH	CR1	
Alarm Contacts for Type GFCB (1-Pole)		
Alarm Contact for GFCB (1-Pole)	W1	
(1) NO and (1) NC	W2	

- ⑥ Add suffix indicated to end of breaker catalog number.
- ⑦ Add amount shown to circuit breaker list price.

Box Sizes **Pages 3-77 through 3-79**
 Discount Symbol **22CD**

Loadcenter Product Selection

Single-Phase and 3-Phase Circuit Breaker Unit Enclosures — 10,000/25,000 Amperes Interrupting Capacity

Table 3-99. Type ECC Circuit Breaker Unit Enclosure — Order Type CC Circuit Breaker Separately

Main Ampere Rating	Unit Enclosure Type	Type of Mounting	Type of Circuit Breaker	Wire Size Range Cu/Al 60°C or 75°C	Catalog Number	Price U.S. \$
Single-Phase 3-Wire — 240 Vac Maximum						
225	Indoor	Flush	CC	⑤	ECC225F ①②③	
225	Indoor	Surface	CC	⑤	ECC225S ①②③	
225	Outdoor	—	CC	⑤	ECC225R ①②③④	

- ① Order circuit breaker separately.
- ② One ground lug accepting (1) #14 – #2 is factory installed. Also, there are pre-drilled holes to accept a GBK5 ground bar.
- ③ Approved for service entrance.
- ④ Rainproof panels are furnished with hub closures plates. For rainproof hubs, refer to **Page 3-63**.
- ⑤ Wire size is determined by the circuit breaker installed in enclosure. Maximum wire size and ampere rating is determined by **Table 3-96**.

Table 3-100. Type CC Circuit Breaker 240 Vac — 10 kAIC for Use in Type ECC Unit Enclosures

Ampere Rating	Wire Size Range Cu/Al 60°C or 75°C for Line Terminals	Type CC 10 kAIC	
		Catalog Number	Price U.S. \$
2-Pole			
100	#4 – 4/0	CC2100	
125		CC2125	
150		CC2150	
175	#2/0 – 300 kcmil	CC2175	
200		CC2200	
225		CC2225	
3-Pole			
100	#4 – 4/0	CC3100	
125		CC3125	
150		CC3150	
175	#2/0 – 300 kcmil	CC3175	
200		CC3200	
225		CC3225	

Table 3-101. Wire/Application Chart

Wire/Application	Maximum Wire Size	Maximum Ampere Rating
Aluminum — Standard	250 kcmil	200
Aluminum — Service Entrance	250 kcmil	225
Copper — Standard and Service Entrance	250 kcmil	225

Table 3-102. Shunt Trips and Auxiliary Contacts

Description		Catalog Number Suffix Adder ⑥	Price U.S. \$ Adder Each
Type	Volts		
Shunt Trip			
CC	12 dc	SR12	
CC	24 dc	SR24	
CC	120 ac	SR01	
CC	208 ac	SR08	
CC	240 ac	SR02	
Auxiliary Contact			
CC (1) NO and (1) NC	—	AL1	

⑥ Add suffix indicated to end of breaker catalog number.

Loadcenter Product Selection

3

Riser Panel



Riser Panel

Product Description

The Cutler-Hammer Riser Panel is a loadcenter with an offset interior to allow riser cables to pass through the enlarged gutter. By using lay-in tap lugs, the contractor is able to simply strip off a length of the riser cable's insulation, and tap off to the riser panel's main lugs. These panels are used in the construction of assisted living homes, dormitories, public housing complexes and apartments.

Eaton offers two 125 ampere main lug riser panels, a 12/24 and a 20/24. The panels are convertible to main breaker

by adding the appropriate breaker and a BREQS125 hold-down kit. Additionally, the 12/24 is offered in a bulk-packed version. The bulk-packed product must be ordered in multiples of 16, and consists of a pallet with uncartoned loadcenters on the bottom, and cartoned trims on top. The entire pallet is shrink-wrapped for protection. By supplying the loadcenter without a carton, the contractor is able to save the unpacking time as well as saving on the scrap cardboard on the site.

For applications higher than 125 amperes, or the circuits provided by the panels above, we offer the BRGUTTER. This is essentially a junction box that mounts next to, and assembles to standard BR or CH loadcenters. There is a matching concentric knockout that allows the tapped cables to pass through from the BRGUTTER to the loadcenter. The trims of the loadcenter and the BRGUTTER are designed to allow the two boxes to bolt to one another in a flush application. There is no need to allow for the trim overhang.

Also offered is the GTAP250, which is a set of three lay-in, insulated tap lugs. The maximum wire size for the GTAP250 is 250 kcmil. GTAP250 can be used with either the riser panels, or the BRGUTTER.



BRGUTTER (Shown with Loadcenter)

Table 3-105. Riser Panel Accessories

Description	Price U.S. \$
BRGUTTER ^② GTAP250	

^② Refer to Page 3-77 for dimensions. BRGUTTER is box size C2.

For riser panels not shown, contact the Flex Center at 1-800-330-6479 for both CH and BR riser panels.

Table 3-103. Riser Panel

Main Ampere Rating	Maximum Number 1-Inch (25.4 mm)		Enclosure Type	Wiring Diagram Figure Number	Box Size	Wire Size Range Cu/Al 60°C or 75°C for Main Lugs	Catalog Number	Price U.S. \$
	Space	Circuits						
125	12	24	Indoor	73	C4	#6 - 2/0	BR1224L125RIS	
125	12	24	Indoor	73	C4	#6 - 2/0	BR1224L125RISBP ^①	
125	20	24	Indoor	74	C4	#6 - 2/0	BR2024L125RIS	

^① Bulk-packaged loadcenter without carton. Must be ordered in multiples of 16.

Mechanical Interlock Cover

Covers mechanically interlock two breakers — Type BW or BWH main breaker with a Type BR.

Table 3-104. Mechanical Interlock Cover

Type	Fits Loadcenter Catalog Numbers	Mechanical Interlock Panel Cover	
		Catalog Number	Price U.S. \$
		Flush	
B	BR816B200RF BR2040B200R BR3040B200R BR4040B200R	BR3RDF5M BR3RDF11M BR3RDF12M BR3RDF13M	
	BR2040B200 BR3040B200 BR4040B200	BRCOV20D1FM BRCOV30G1FM BRCOV40L1FM	



Type B

Discount Symbol 22CD

Product Description

Type BR Retrofit Interior Kits

3

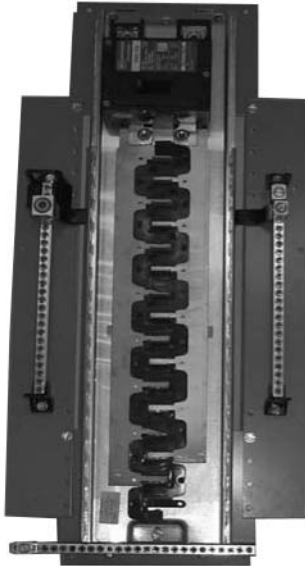

Type BR Retrofit Interior

Product Description

Replacing existing loadcenters and panelboards can be a time consuming and expensive job. BR retrofit kits can be the solution to save time and money. The kit consists of a standard trim to fit the interior, a picture frame trim to fit the existing box, and a field adjustable interior assembly which includes neutral and ground bars as well. These are especially applicable when the existing box is flush mounted in drywall, plaster or block wall. The existing box, and many times existing wiring, can remain. Interiors are UL recognized under UL 67, Panelboard standard.



Cutler-Hammer Quick-ProSM

All you need to know to save time and make more money. Specified on certain Cutler-Hammer products, the Quick-Pro symbol allows for immediate recognition of products that are designed for straightforward installation. When you see Quick-Pro, you know you can install quickly — sometimes up to 50% less than the usual installation time — and move onto your next job.

Detailed Product Guide

All standard retrofit kits are suitable for a range of existing box sizes:

- Box width ranging from 14.50 to 22.00 inches (368.3 to 558.8 mm).
- Box depth ranging from 4.00 inches (101.6 mm) for BR.
- Box height ranging from 21.00 to 45.00 inches (533.4 to 1143.0 mm).

For box dimensions outside of these ranges contact the Lincoln Flex Center at 800-330-6479. Be sure to provide the existing incoming line wire size.

To select the retrofit kit:

1. From the existing box size determine which retrofit groups are suitable (may be more than one).
2. Use type of interior, number of phases, and type of main to find the selection chart.
3. Select part number from chart (if main breaker, replace XXX with specific amp rating).
4. Note that the overlap of the existing wall is the retro cover size minus the existing box size. If specific measurements are needed, communicate that you need a custom trim size.
5. Contact the **Lincoln Flex Center at 800-330-6479** for pricing, lead-times, and order entry instructions.

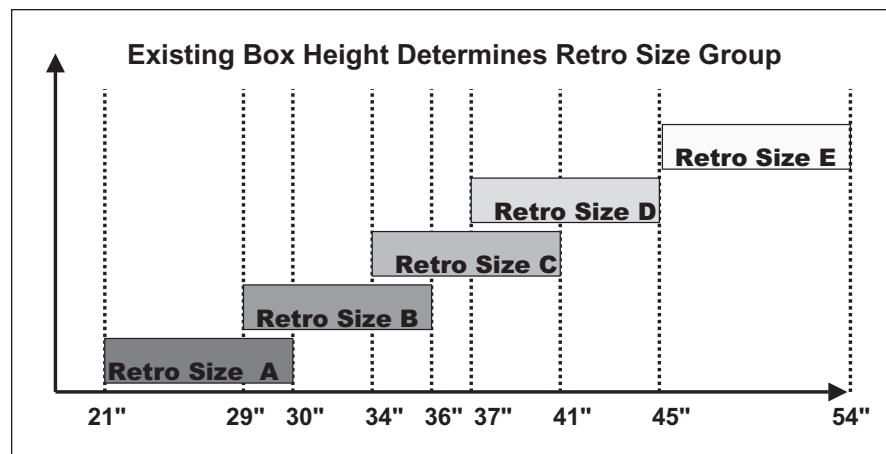

Figure 3-16. Retro Size Groups

Product Selection

Table 3-106. Type BR Interior — Dimensions in Inches (mm)

Main Breaker Rating		Existing Box Height		Wire Size	Number of Circuits	Part Number	Retro Size Group	Retro Cover Size ^①	
Amperes	AIC	Minimum	Maximum					Height	Width
Single-Phase with Main Breaker									
60 – 125	10K 22K	21.00 (533.4)	30.00 (762.0)	#4 – 2/0 #4 – 2/0	20	RABR20BXXX ^② RABR20HXXX ^②	A	33.00 (838.2)	24.00 (609.6)
60 – 125	10K 22K	29.00 (736.6)	36.00 (914.4)	#4 – 1/0 #4 – 1/0	30	RBBR30BCXXX ^② RBBR30HCXXX ^②	B	40.00 (1016.0)	24.00 (609.6)
100 – 200	25K	29.00 (736.6) 31.00 (787.4)	30.50 (774.7) 36.00 (914.4)	#2 – 250 kcmil #2 – 300 kcmil	20	RBBR20HXXX ^②			
100 – 225	25K	34.00 (863.6) 36.00 (914.4)	35.50 (901.7) 41.00 (1041.4)	#2 – 250 kcmil #2 – 300 kcmil	30	RCBR30HXXX ^②	C	43.00 (1092.2)	24.00 (609.6)
100 – 225	25K	37.00 (939.8) 39.00 (990.6) 41.00 (1041.4)	38.50 (977.9) 40.50 (1028.7) 45.00 (1143.0)	#2 – 4/0 #2 – 250 kcmil #2 – 300 kcmil	40	RDBR40HXXX ^②	D	47.00 (1193.8)	24.00 (609.6)
Three-Phase with Main Breaker									
60 – 100	10K 22K	21.00 (533.4)	30.00 (762.0)	#4 – 2/0 #4 – 2/0	12	RABR12B3XXX ^② RABR12H3XXX ^②	A	33.00 (838.2)	24.00 (609.6)
60 – 100	10K 22K	29.00 (736.6)	36.00 (914.4)	#4 – 1/0 #4 – 1/0	30	RBBR30BXXX ^② RBBR30H3XXX ^②	B	40.00 (1016.0)	24.00 (609.6)
100 – 200	10K	37.00 (939.8)	45.00 (1143.0)	2/0 – 300 kcmil	30	RDBR30B3XXX ^②	D	47.00 (1193.8)	24.00 (609.6)
	100K	37.00 (939.8) 39.00 (990.6)	38.50 (977.9) 45.00 (1143.0)	2/0 – 250 kcmil 2/0 – 300 kcmil		RDBR30H3XXX ^②			
100 – 225	10K 100K	34.00 (863.6) 36.00 (914.4)	35.50 (901.7) 41.00 (1041.4)	2/0 – 250 kcmil 2/0 – 300 kcmil	42	REBR42B3XXX ^② REBR42H3XXX ^②	E	56.00 (1422.4)	24.00 (609.6)

^① Specific cover sizes are available. Be sure to specify the custom cover option and provide exact dimensions required.

^② XXX is for Main Breaker specific ampere rating.

Table 3-107. Type BR Interior — Dimensions in Inches (mm)

Maximum Bus Ampere Rating	Existing Box Height		Wire Size	Number of Circuits	Part Number	Retro Size Group	Retro Cover Size ^③	
	Minimum	Maximum					Height	Width
Single-Phase Main Lug Only								
125	21.00 (533.4)	30.00 (762.0)	#14 – 2/0	24	RABR20L125	A	33.00 (838.2)	24.00 (609.6)
200	29.00 (736.6)	31.50 (800.1)	#1 – 250 kcmil	30	RBBR30L200	B	40.00 (1016.0)	24.00 (609.6)
	32.00 (812.9)	36.00 (914.4)	#1 – 300 kcmil					
200	34.00 (863.6)	36.50 (927.1)	#1 – 250 kcmil	40	RCBR40L200	B	43.00 (1092.2)	24.00 (609.6)
	37.00 (939.8)	41.00 (1041.4)	#1 – 300 kcmil					
200	37.00 (939.8)	38.50 (977.9)	#1 – 250 kcmil	42	RDBR42L225	B	47.00 (1193.8)	24.00 (609.6)
	39.00 (990.6)	45.00 (1143.0)	#1 – 300 kcmil					
Three-Phase Main Lug Only								
125	21.00 (533.4)	30.00 (762.0)	#8 – 2/0	24	RABR12L3125	A	33.00 (838.2)	24.00 (609.6)
100	29.00 (736.6)	36.00 (914.4)	#8 – 2/0	24	RBBR30L3100	B	40.00 (1016.0)	24.00 (609.6)
150			#4 – 4/0	24	RBBR24L3150			
200	34.00 (863.6)	35.50 (901.7)	#4 – 250 kcmil	30	RCBR30L3200	C	43.00 (1092.2)	24.00 (609.6)
	36.00 (914.4)	41.00 (1041.4)	#4 – 300 kcmil					
225	37.00 (939.8)	38.50 (977.9)	#4 – 250 kcmil	42	RDBR42L3225	D	47.00 (1193.8)	24.00 (609.6)
	39.00 (990.6)	45.00 (1143.0)	#4 – 300 kcmil					
225	45.00 (1143.0)	54.00 (1371.6)	#4 – 300 kcmil	42	REBR42L3225	E	56.00 (1422.4)	24.00 (609.6)

^③ Specific cover sizes are available. Be sure to specify the custom cover option and provide exact dimensions required.

Product Description

BR Renovation Loadcenter Value Packs

3

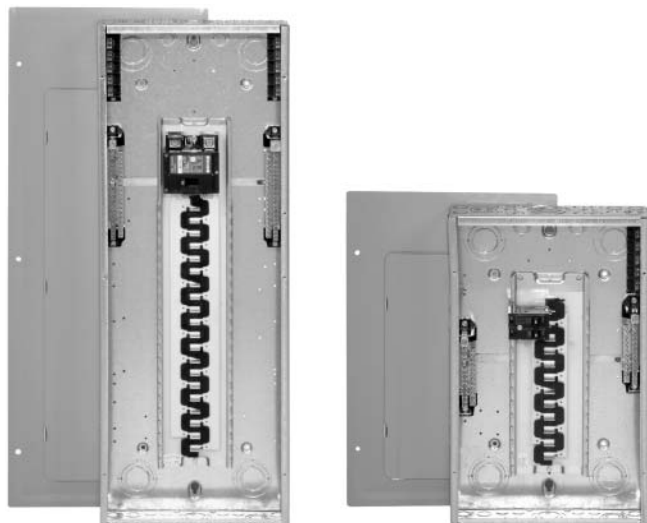

BR Renovation Loadcenters

Product Description

- Available in 10, 20, 30 and 40 circuit main breaker styles.
- Designed to replace existing loadcenters and fuse boxes.
- Type BR loadcenter packaged with circuit breakers.
- Factory-installed 5-circuit terminal block(s).
- Twin-stacked neutral design.

Features, Functions & Benefits

- Factory-installed terminal block(s) allows installer to terminate existing short wires without using wire nuts or junction boxes.
- Twin-stacked neutrals are mounted up high in the loadcenter, which allows for all neutral and ground wires to be terminated in the top half of the loadcenter.
- Specifically designed for the service contractor — this is the **ONLY** renovation line in the industry.
- Single-pole and two-pole breakers included.
- 10-year warranty on loadcenter and breakers.

Product Selection

Table 3-108. BR Value Packs

Main Breaker Type	Description	Wire Size Range	Number of 5-Circuit Terminal Blocks	Single-Pole Breakers	Two-Pole Breakers	Catalog Number	UPC Code
BR 10 kAIC	Single-Phase 100 Ampere 10 k Main Breaker 10/20 Circuit Surface-Mount Box is 11.75" Wide x 13" Tall	#6 – 1/0	0	(2) BR115	(1) BR230	BR1020B100S11RN	782116417070
	Single-Phase 100 Ampere 10 k Main Breaker 10/20 Circuit Flush-Mount Box is 11.75" Wide x 13" Tall		0	(2) BR115	(1) BR230	BR1020B100F11RN	782116417087
BWH 25 kAIC	Single-Phase 100 Ampere 10 kAIC Main Breaker 20/20 Circuit	#2 – 300 kcmil	1	(5) BR120	(1) BR230	BR2020B100RN	782116417094
	Single-Phase 200 Ampere 10 kAIC Main Breaker 30/40 Circuit		2	(5) BR115 (5) BR120	(1) BR230 (1) BR250	BR3040B200RN	782116417100
	Single-Phase 200 Ampere 10 kAIC Main Breaker 40/40 Circuit		2	(6) BR115 (6) BR120	(1) BR230 (1) BR250	BR4040B200RN	782116417117

Note: Indoor enclosure type.



Cutler-Hammer Quick-ProSM

All you need to know to save time and make more money. Specified on certain Cutler-Hammer products, the Quick-Pro symbol allows for immediate recognition of products that are designed for straightforward installation. When you see Quick-Pro, you know you can install quickly — sometimes up to 50% less than the usual installation time — and move onto your next job.

Loadcenter Options and Accessories

Table 3-109. Field Installation Kits and Parts

Number of Poles	Ampere Rating	Number of 1-Inch (25.4 mm) Spaces Needed	Wire Size Range Cu/Al 60°C or 75°C	Ordering Quantity ①	Catalog Number	Price U.S. \$ Each
2	125	2	#8 – 2/0	1	BRSF125	
	150	2	#8 – 2/0	1	BRSF150	
	225	4	#2 – 300 kcmil	1	BRS225	
3	150	3	#8 – 2/0	1	3BRSF150	
	225	6	#2 – 300 kcmil	1	3BRS225	
Main Lugs 2-Pole, 200 Ampere Stud Mounted (Includes Deadfront Filler Plate)			#1 – 300 kcmil	1	BRL200	
Neutral/Ground Lug Add-On Neutral or Ground Lug			#2/0 Maximum #3/0 Maximum 300 kcmil Maximum	1 1 1	NL20 NL30 NL300	
Filler Plates 1-Inch (25.4 mm) Circuit Breaker Space				25	BRFP	
BW Main Circuit Breaker Space (with Hardware)				1	BWFP	
Door Lock — 12 through 42 Circuits, and 100 through 225 Amperes				1	TDL	
Door Lock — 4 through 8 Circuits, 125 Amperes				1	CH9FL	
ANSI-61 Light Gray Touchup Paint for Current Loadcenters				1	SPC61	
Isolated Neutral Assembly (Computer Circuits)				1	BINA	
Circuit Directory — Adhesive Backed				10	TCD	
Cover Screws				25	LCCS	
Cover Replacement Latch (Gray) 14-5/16 (363.5 mm) Wide Loadcenters Only				1	BRRL	
Circuit Marking Strip (Next to Breaker)				10	BRMS	
Circuit Identification Label (Preprinted Breaker Labels)				25	CHBL	
Series Rated Caution Label				25	SRL	
Bonding Strip with Screw				1	BSSUSE	

① Must be purchased in multiples of ordering quantities indicated.

Table 3-110. Field Installation Rainproof Conduit Hubs

Description	Conduit Size Inches (mm)	Ordering Quantity ②	Catalog Number	Price U.S. \$ Each
Group 1 — For use with 70, 100 and 125 Ampere MLO and MCB Loadcenters and Circuit Breaker Enclosures and the following 150 and 200 Ampere Panels: BR816B150RF, BR816B200RF	.75 (19.1)	1	DS075H1	
	1.00 (25.4)	1	DS100H1	
	1.25 (31.8)	1	DS125H1	
	1.50 (38.1)	1	DS150H1	
	2.00 (50.8)	1	DS200H1	
Group 2 — For use with 150, 200 and 225 Ampere MLO and MCB Loadcenters and Circuit Breaker Enclosures except for the following 200 Ampere Loadcenters: BR48B200RF. Also for use with 400 and 600 Ampere Loadcenters and New York City Loadcenters Manufactured after November 1, 2005	2.00 (50.8)	1	DS200H2	
	2.50 (63.5)	1	DS250H2	
	3.00 (76.2)	1	DS300H2	
Type H Conduit Hubs for Loadcenters PL0724R and S3100RN	.75 (19.1)	1	RH75P	
	1.00 (25.4)	1	RH100P	
	1.25 (31.8)	1	RH125P	
	1.50 (38.1)	1	RH150P	
Adapter Kit — Allows Installing a Group 1 Hub on Devices Arranged for Group 2 Hubs	—	1	DS900AP	
Group 1 Small Blank Hub Plate with Bump	—	1	DS900CP1	
Group 2 Large Blank Hub Plate with Bump	—	1	DS900CP2	

② Must be purchased in multiples of ordering quantities indicated.



BRSF125



3BRS225



BRL200



TDL



DS300H2

**Plug-on Circuit Breakers, Types BR
10,000/22,000/42,000 Amperes
Interrupting Capacity 120 Vac, 120/240 Vac and 240 Vac**



BR120





BR215



BR320

Table 3-112. Type BR Breakers, 1-Inch (25.4 mm) per Pole 120/240, 10,000, 22,000 and 42,000 AIC

Ampere Rating	Wire Size Range Cu/Al 60°C or 75°C	1-Pole 120/240 Vac Requires One 1-Inch (25.4 mm) Space 				2-Pole 120/240 Vac Common Trip Requires Two 1-Inch (25.4 mm) Spaces 					
		10 per Shelf Carton				5 per Shelf Carton					
		10 kAIC		22 kAIC		10 kAIC		22 kAIC		42 kAIC	
		Catalog Number	Price U.S. \$	Catalog Number	Price U.S. \$	Catalog Number	Price U.S. \$	Catalog Number	Price U.S. \$	Catalog Number	Price U.S. \$
10	#14 - 4	BR110		—		BR210		—		—	
15		BR115 ^{①②}		BRH115		BR215 ^③		BRH215		—	
20		BR120 ^{①②}		BRH120		BR220 ^③		BRH220		—	
25		BR125		BRH125		BR225 ^③		BRH225		—	
30		BR130		BRH130		BR230 ^③		BRH230		—	
35	#14 - 4	BR135		BRH135		BR235 ^③		BRH235		—	
40		BR140		BRH140		BR240 ^③		BRH240 ^③		—	
45		—		BRH145		BR245 ^③		BRH245		—	
50		BR150		BRH150		BR250 ^③		BRH250 ^③		—	
55	#14 - 3	BR150		BRH155		BR255		BRH255		—	
60	#4 - 1/0	BR160		BRH160		BR260		BRH260		BRHH260	
70		BR170		BRH170		BR270		BRH270		BRHH270	
80		—		—		BR280		BRH280		BRHH280	
90		—		—		BR290		BRH290		BRHH290	
100		—		—		BR2100		BRH2100		BRHH2100	
110		—		—		BR2110		BRH2110		BRHH2110	
125	#4 - 2/0	—		—		BR2125		BRH2125		BRHH2125	
150		—		—		BR2150 ^④		—		—	

- ① One pole, 1-inch (25.4 mm) per pole circuit breakers are available with high magnetic setting for switching large tungsten lamp loads. Add suffix H to catalog number.
- ② Switching duty rated.
- ③ On the black handle breaker, add suffix "B" to the catalog number and \$4.00 to the list price to obtain a tapped molded opening for proper use with hold-down kits.
- ④ For use as a branch circuit breaker in 400 and 600 ampere panels only.

Note: All Type BR 1-, 2-, and 3-pole circuit breakers carry listing for HACR application.
For circuit breakers with a shunt trip, add ST suffix and obtain pricing from table on **Page 3-76**.

Circuit Breaker Product Selection

Table 3-113. Type BR Breakers, 1-Inch (25.4 mm) per Pole 240 Vac, 10,000, 22,000 and 42,000 AIC

Ampere Rating	Wire Size Range Cu/Al 60°C or 75°C	3-Pole 240 Vac Common Trip Requires Three 1-Inch (25.4 mm) Spaces			
		5 per Shelf Carton			
		10 kAIC		22 kAIC	
		Catalog Number	Price U.S. \$	Catalog Number	Price U.S. \$
10 15 20 25 30	#14 – 4	BR310 BR315 ① BR320 ① BR325 BR330		— BRH315 BRH320 BRH325 BRH330	
35 40 45 50	#14 – 4	BR335 BR340 BR345 BR350		BRH335 BRH340 BRH345 BRH350	
55	#14 – 3	BR355		BRH355	
60 70 80 90 100	#4 – 1/0	BR360 BR370 BR380 BR390 BR3100		BRH360 BRH370 BRH380 BRH390 BRH3100	

① One pole, 1-inch (25.4 mm) per pole circuit breakers are available with high magnetic setting for switching large tungsten lamp loads. Add suffix H to catalog number.

Note: All Type BR 1-, 2- and 3-pole circuit breakers carry listing for HACR application. For circuit breakers with a shunt trip, add ST suffix and obtain pricing from table on **Page 3-76**.

Plug-on Branch Feeder Type Arc Fault Circuit Breakers, Type BR 10,000 Amperes Interrupting Capacity 120 Vac and 120/240 Vac



Type BR AFCI Circuit Breaker

A Branch Feeder Type Arc Fault Circuit Interrupter is a device intended to mitigate parallel arcing faults in the complete circuit, including connected cords. Parallel arcing faults can occur from line to neutral or line to ground. These arcing faults are in parallel with the load and produce the most energy of all arcing faults.

The Branch Feeder Type AFCI is required in the 1999, 2002 and 2005 National Electrical Code.

As of January 1, 2008, the Combination Type AFCI is required.

Product Selection

Table 3-114. Type BR, 1-Inch (25.4 mm) wide FIRE-GUARD™ AFCI Circuit Breakers

Poles	Ampere Rating	Configuration	Catalog Number	Price U.S. \$
Single-Pole 10 kAIC	15	AFCI AFCI with GFCI	BR115AF ① BR115AFGF	
	20	AFCI AFCI with GFCI	BR120AF ① BR120AFGF	
Single-Pole 22 kAIC	15	AFCI	BRH115AF	
	20	AFCI	BRH120AF	
Double-Pole 10 kAIC ②③	15	AFCI Common Trip AFCI Independent Trip AFCI Common Trip with GFCI	BR215AF BR215AFIT BR215AFGF	
	20	AFCI Common Trip AFCI Independent Trip AFCI Common Trip with GFCI	BR220AF BR220AFIT BR220AFGF	

- ① Clamshell packaging available with CS modification code on the end of catalog number.
- ② Common trip refers to 2-pole 240 volt load application sourced by 120/240 Vac (see **Figure 3-19**).
- ③ Independent trip refers to 2-pole multi-wire, home run or shared neutral circuits (see **Figure 3-18** and **Figure 3-20**).

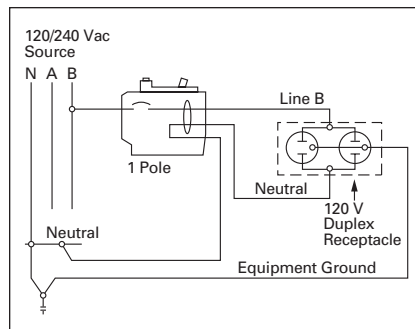

Figure 3-17. 1-Pole 120 Volt Load Application Sourced by 120/240 Vac

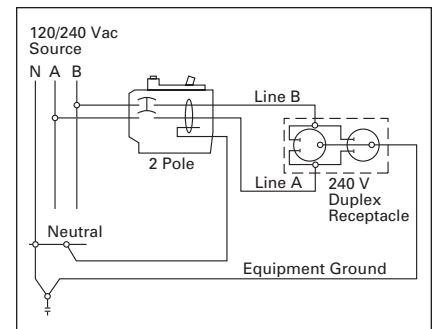

Figure 3-19. 2-Pole 240 Volt Load Application Sourced by 120/240 Vac

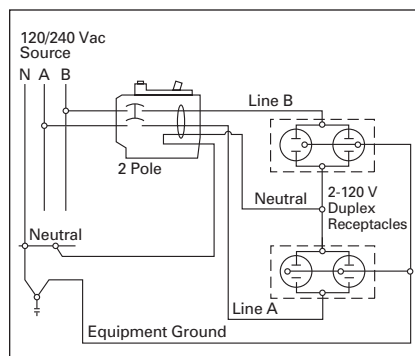

Figure 3-18. 2-Pole Shared Neutral with Multi-Duplex Receptacle Application

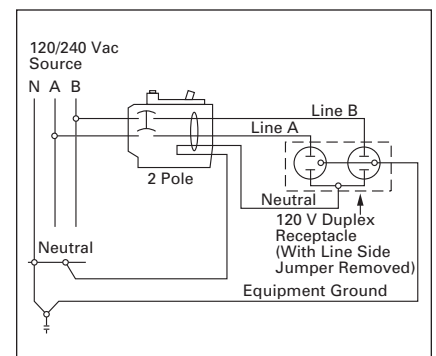

Figure 3-20. 2-Pole Shared Neutral with Duplex Receptacle Application

Plug-on Combination Type Arc Fault Circuit Breakers, Type BR 10,000 Amperes Interrupting Capacity 120 Vac and 120/240 Vac

3



Type BR AF CI Circuit Breaker

A Combination Type Arc Fault Circuit Interrupter is a device that includes all of the protection offered by the Branch Feeder AFCI (mitigation of parallel arcing faults in the complete circuit, including connected cords). In addition it provides direct detection of persistent low current arcing faults down to 5 amps with associated mitigation of fire hazards in the cords connected to the outlets. Parallel arcing faults can occur from line to neutral or line to ground. These arcing faults are in parallel with the load and produce the most energy of all arcing faults. The current level of low current arcing faults is limited by the load.

Product Selection

Table 3-115. Type BR, 1-Inch (25.4 mm) wide FIRE-GUARD™ Combination Type AFCI Circuit Breakers

Poles	Ampere Rating	Configuration	Catalog Number	Price U.S. \$
Single-Pole 10 kAIC	15	AFCI	BR115CAF ①	
	20	AFCI	BR120CAF ①	

① Clamshell packaging available with CS modification code on the end of catalog number.

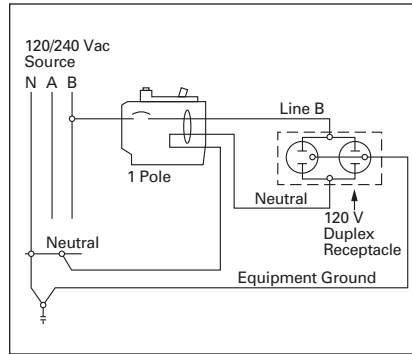
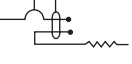



Figure 3-21. 1-Pole 120 Volt Load Application Sourced by 120/240 Vac

Plug-on Ground Fault Circuit Breakers, Type GFCB and GFEP
10,000/22,000 Amperes Interrupting Capacity
120 Vac and 120/240 Vac

Table 3-116. Type GFCB Ground Fault Circuit Breakers — 5 Milliampere —
1-Inch (25.4 mm) per Pole 120 Vac or 120/240 Vac, 10,000 AIC

Ampere Rating	Wire Size Range Cu/Al 60°C or 75°C	1-Pole 120 Vac Requires One 1-Inch (25.4 mm) Space		2-Pole 120/240 Vac Common Trip Requires Two 1-Inch (25.4 mm) Spaces	
					
		1 per Shelf Carton		1 per Shelf Carton	
		10,000 AIC		10,000 AIC	
		Catalog Number ①	Price U.S. \$	Catalog Number	Price U.S. \$
15 20 25 30 40 50	#14 - 4	GFCB115 GFCB120 GFCB125 GFCB130 GFCB140 —		GFCB215 GFCB220 GFCB225 GFCB230 GFCB240 GFCB250 ②	



Type GFCB 1-Pole



Type GFCB 2-Pole

① Available with bell alarm or auxiliary switch. See circuit breaker accessories on Page 3-75.
 ② For use with copper wire only.

Table 3-117. Type GFCBH Ground Fault Breakers — 5 Milliampere —
1-Inch (25.4 mm) per Pole 120 Vac or 120/240 Vac, 22,000 AIC



Ampere Rating	Wire Size Range Cu/Al 60°C or 75°C	1-Pole 120 Vac Requires One 1-Inch (25.4 mm) Space		2-Pole 120/240 Vac Common Trip Requires Two 1-Inch (25.4 mm) Spaces	
					
		1 per Shelf Carton		1 per Shelf Carton	
		22,000 AIC		22,000 AIC	
		Catalog Number	Price U.S. \$	Catalog Number	Price U.S. \$
15 20 25 30	#14 - 4	GFCBH115 GFCBH120 GFCBH125 GFCBH130		GFCBH215 GFCBH220 GFCBH225 GFCBH230	

Table 3-118. Type GFEP Ground Fault Equipment Protectors — 30 Milliampere —
1-Inch (25.4 mm) per Pole 120 Vac or 120/240 Vac, 10,000 AIC

Ampere Rating	Wire Size Range Cu/Al 60°C or 75°C	1-Pole 120 Vac Requires One 1-Inch Space		2-Pole 120/240 Vac Common Trip Requires Two 1-Inch Spaces	
					
		1 per Shelf Carton		1 per Shelf Carton	
		10,000 AIC		10,000 AIC	
		Catalog Number	Price U.S. \$	Catalog Number	Price U.S. \$
15 20 25 30 40 50	#14 - 4	GFEP115 GFEP120 GFEP125 GFEP130 — —		GFEP215 GFEP220 GFEP225 GFEP230 GFEP240 GFEP250 ③	

③ For use with copper wire only.

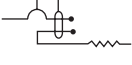
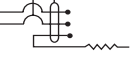
Special Application Circuit Breaker Product Selection

Ground Fault Application Notes

Single-pole GFCBs are designed for use in 2-wire, 120 Vac circuits.

Figure 3-22 shows a typical wiring configuration.

Two-pole GFCBs are designed for use in 3-wire, 120/240 Vac circuits, 120 Vac multiwire circuits employing common, neutral and 2-wire, 240 Vac circuits obtained from a 120/240 Vac source.

Figure 3-23 and **Figure 3-24** illustrate typical wiring configurations for a 120/240 Vac multiwire circuits.

Figure 3-25 depicts a 240 Vac, 2-wire circuit. Note the “panel neutral” conductor connects to the neutral bar, even though the neutral is not included in the load circuit. This connection is necessary to supply a 120 Vac power source to the ground fault sensing circuit.

The figures are shown with a 120/240 Vac, single-phase, 3-wire power source, but are also applicable to a 120/208 Vac, 3-phase, 4-wire power supply. For all figures, the electrical operation of the GFCB is not affected by the equipment ground.

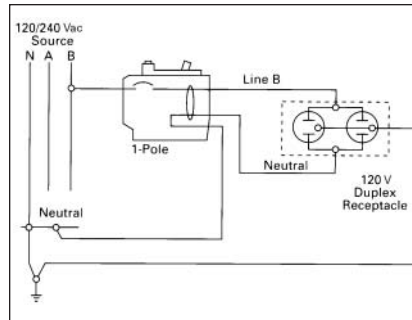

Figure 3-22. 1-Pole 120 Volt Duplex Receptacle Application

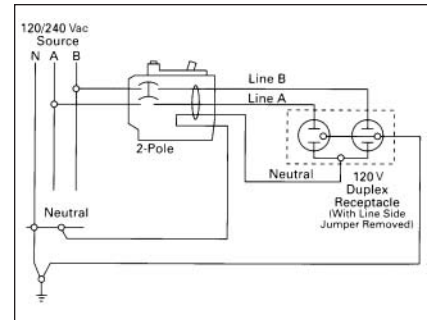

Figure 3-24. 2-Pole 120 Volt Duplex Receptacle Application

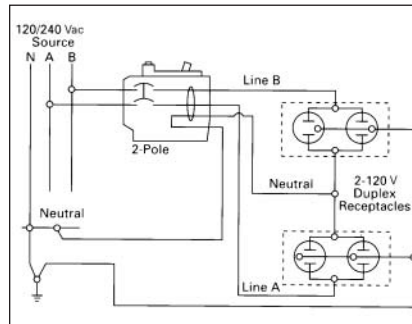

Figure 3-23. 2-Pole 120 Volt Multi-Duplex Receptacle Application

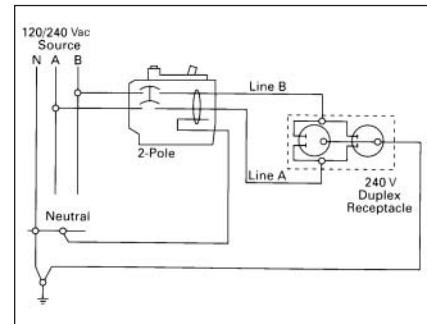

Figure 3-25. 2-Pole 240 Volt Duplex Receptacle Application

CTL Plug-on Circuit Breakers, Type BD Duplex, BQ and BQC Quadplex
10,000 Amperes Interrupting Capacity 120/240 Vac



BD2020



BQ2302115

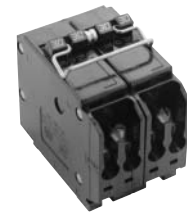

BQ230230

Duplex and Independent Trip Quadplex Breakers

Table 3-119. Class CTL, 1-Inch (25.4 mm) per Pole 10,000 AIC — All Circuit Breakers Have Rejection Tab Feature

Type BD Duplex (UL Type BRD)			Wire Size Range Cu/Al 65°C or 75°C	Type BQ Quadplex Independent Trip (UL Type BRD)				Type BQ Quadplex Independent Trip (UL Type BRD)				
1-Pole ②				2-Pole ① and 1-Pole ②				2-Pole				
Requires One 1-Inch (25.4 mm) Space			Requires Two 1-Inch (25.4 mm) Spaces				Requires Two 1-Inch (25.4 mm) Spaces					
10 per Shelf Carton			5 per Shelf Carton				5 per Shelf Carton					
Ampere Rating	10,000 AIC		10,000 AIC				10,000 AIC					
	120 Vac		120 Vac	120/240 Vac	120 Vac	Catalog Number	Price U.S. \$	120/240 Vac		Catalog Number	Price U.S. \$	
Catalog Number		Ampere Rating		Ampere Rating				Ampere Rating				
		Outer Left 1-Pole	Center 2-Poles Independent Trip	Outer Right 1-Pole			Outer 2-Poles Independent Trip	Center 2-Poles Independent Trip				
10 – 10	BD1010		#14 – 4	15	20	15	BQ2202115		15	15	BQ215215	
15 – 15	BD1515			20	20	20	BQ2202120		15	20	BQ215220	
15 – 20	BD1520			15	30	15	BQ2302115		15	30	BQ215230	
15 – 30	BD1530			20	30	20	BQ2302120		15	40	BQ215240	
20 – 15	BD2015			15	40	15	BQ2402115		15	50	BQ215250	
20 – 20	BD2020			20	40	20	BQ2402120		20	20	BQ220220	
20 – 30	BD2030			15	50	15	BQ2502115		20	30	BQ220230	
25 – 25	BD2525			20	50	20	BQ2502120		20	40	BQ220240	
30 – 15	BD3015			—	—	—	—		20	50	BQ220250	
30 – 20	BD3020			—	—	—	—		25	25	BQ225225	
30 – 30	BD3030			—	—	—	—		30	30	BQ230230	
30 – 40	BD3040			—	—	—	—		30	40	BQ230240	
30 – 50	BD3050			—	—	—	—		30	50	BQ230250	
50 – 30	BD5030			—	—	—	—		40	40	BQ240240	
50 – 50	BD5050			—	—	—	—		40	50	BQ240250	
—	—			—	—	—	—		50	50	BQ250250	
—	—			—	—	—	—		—	—	—	
—	—			—	—	—	—		—	—	—	

① All Type BD Duplex and BQ Quadplex circuit breakers carry listing for HACR applications.

② All 15 and 20 ampere single poles are switch-duty rated.

Special Application Circuit Breaker Product Selection

**Non-CTL Plug-on Replacement
 Circuit Breakers, Type BRD
 10,000 Amperes Interrupting
 Capacity 120/240 Vac**

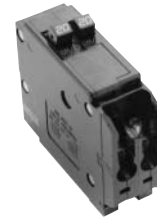

**Non-CTL 10,000 AIC for
 Replacement Purposes Only**

For replacement in enclosures manufactured prior to 1968 with unnotched stabs. Circuit breakers do not have rejection tab.

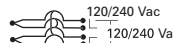

BR1515

Table 3-120. Class Non-CTL, 1-Inch (25.4 mm) per Pole 10,000 AIC — Breakers Do Not Have Rejection Tab Feature

Type BR Duplex			Wire Size Range Cu/Al 65°C or 75°C	Type Brand BRD Quadplex Independent Trip				Type BRD Quadplex Common Trip center and Outer Poles			
1-Pole 				2-Pole 				2-Pole 			
Requires One 1-Inch (25.4 mm) Space			Requires Two 1-Inch (25.4 mm) Spaces				Requires Two 1-Inch (25.4 mm) Spaces				
10 per Shelf Carton			5 per Shelf Carton				5 per Shelf Carton				
Ampere Rating	10,000 AIC		10,000 AIC				10,000 AIC				
	120 Vac		120/240 Vac	120/240 Vac	Catalog Number	Price U.S. \$	120/240 Vac	120/240 Vac	Catalog Number	Price U.S. \$	
	Catalog Number	Price U.S. \$	Ampere Rating	Ampere Rating			Ampere Rating	Ampere Rating			
			Outer 2-Poles Independent Trip	Center 2-Poles Independent Trip			Outer 2-Poles Common Trip	Center 2-Poles Common Trip			
15 – 15	BR1515		#14 – 4	15	15	BR415	15	15	BRDC215215		
15 – 20	BR1520			20	20	BR420	30	30	BRDC230230		
20 – 15	BR2015			30	30	BR430	30	40	BRDC230240		
20 – 20	BR2020			20	30	BRD220230	30	50	BRDC230250		
30 – 30	BR3030			30	40	BRD230240	—	—	—		
30 – 50	BR3050			30	50	BRD230250	—	—	—		

Note: Type BD Duplex, BQ and BQC Quadplex (CTL) circuit breakers conform to Section 384-15 of the latest National Electrical Code. Install breaker only in panel positions that have notched bus stabs.

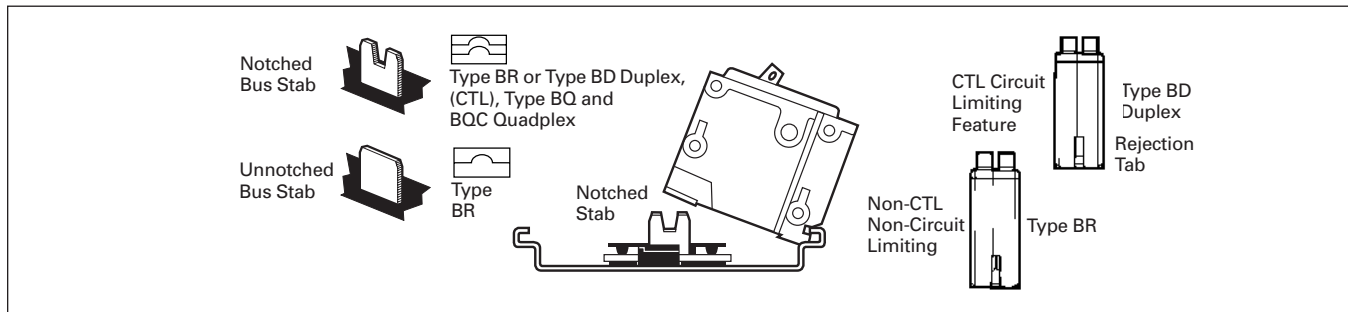

Figure 3-26. CTL and Non-CTL Breakers

Common Trip Quadplex Breakers



BQC2302115



BQC230230

Table 3-121. Class CTL, 1-Inch (25.4 mm) per Pole 10,000 AIC — All Circuit Breakers Have Rejection Tab Feature

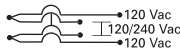
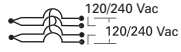
Type BQC Quadplex Common Trip Center Poles (UL Type BRD)					Wire Size Range Cu/Al 65°C or 75°C	Type BQC Quadplex Common Trip Center and Outer Poles (UL Type BRD)				
2-Pole ① and 1-Pole ②						2-Pole ①				
Requires Two 1-Inch (25.4 mm) Spaces					Requires Two 1-Inch (25.4 mm) Spaces					
5 per Shelf Carton					5 per Shelf Carton					
10,000 AIC					10,000 AIC					
120 Vac	120/240 Vac	120 Vac	Catalog Number	Price U.S. \$		120/240 Vac	Catalog Number	Price U.S. \$		
Ampere Rating					Ampere Rating					
Outer Left 1-Pole	Center 2-Poles Common Trip	Outer Right 1-Pole			Outer 2-Poles Common Trip	Center 2-Poles Common Trip				
15	20	15	BQC2202115		#14 - 4	15	15	BQC215215		
15	25	15	BQC2252115			15	20	BQC215220		
15	30	15	BQC2302115			15	30	BQC215230		
15	40	15	BQC2402115			20	15	BQC220215		
15	50	15	BQC2502115			20	20	BQC220220		
—	—	—	—			20	30	BQC220230		
—	—	—	—			20	40	BQC220240		
—	—	—	—			20	50	BQC220250		
20	15	20	BQC2152120		#14 - 4	25	25	BQC225225		
20	20	20	BQC2202120			25	30	BQC225230		
20	25	20	BQC2252120			30	15	BQC230215		
20	30	20	BQC2302120			30	30	BQC230230		
20	40	20	BQC2402120			30	40	BQC230240		
20	50	20	BQC2502120			30	50	BQC230250		
30	50	20	BQC2502030		#14 - 4	40	30	BQC240230		
—	—	—	—			40	40	BQC240240		
—	—	—	—			40	50	BQC240250		
—	—	—	—			50	20	BQC250220		
—	—	—	—			50	50	BQC250250		

① All Type BQC Quadplex circuit breakers carry listing for HACR applications.

② All 15 and 20 ampere single poles are switch-duty rated.

Circuit Breaker Product Selection

Plug-on Circuit Breakers, Types BJ and BJH
10,000/22,000 Amperes Interrupting Capacity
120/240 Vac and 240 Vac

For Use in Single-Phase and 3-Phase Loadcenters
 150 Amperes and Above



Type BJ

Table 3-122. Types BJ and BJH Breakers, 1-Inch (25.4 mm) per Pole, 120/240 or 240 Vac, 10,000, 22,000 AIC

Ampere Rating	2-Pole 120/240 Vac Common Trip Requires Four 1-Inch (25.4 mm) Spaces ①				Wire Size Range Cu/Al 60°C or 75°C	3-Pole 240 Vac Common Trip Requires Six 1-Inch (25.4 mm) Spaces ②			
	10 per Shelf Carton					5 per Shelf Carton			
	10,000 AIC		22,000 AIC			10,000 AIC		22,000 AIC	
	Catalog Number	Price U.S. \$	Catalog Number	Price U.S. \$		Catalog Number	Price U.S. \$	Catalog Number	Price U.S. \$
125	BJ2125		BJH2125		#2 – 300 kcmil	BJ3125		BJH3125	
150	BJ2150		BJH2150			BJ3150		BJH3150	
175	BJ2175		BJH2175			BJ3175		BJH3175	
200	BJ2200		BJH2200			BJ3200		BJH3200	
225	BJ2225		BJH2225			BJ3225		BJH3225	

① Breaker uses two 1-inch (25.4 mm) pole spaces on left side and two 1-inch (25.4 mm) pole spaces on right side of loadcenter.
 ② Breaker uses three 1-inch (25.4 mm) pole spaces on left side and three 1-inch (25.4 mm) pole spaces on right side of loadcenter.
Note: If BJ or BJH breakers are used as a main or a back feed device, a hold-down kit is required. See Page 3-75.

Plug-on Special Application Circuit Breakers
10,000 Amperes Interrupting Capacity
120 Vac, 120/240 Vac and 240 Vac



BRWH215
Water Heater Breaker



BRSN220
Switching Neutral Breaker

Table 3-123. Special Application Circuit Breakers, 1-Inch (25.4 mm) per Pole

Water Heater Breakers			Switching Neutral Breakers			Wire Size Range Cu/Al 60°C or 75°C	240 V Breakers			Non-Automatic Molded Case Switches		
2-Pole 120/240 Vac Common Trip Requires Two 1-Inch (25.4 mm) Spaces			2-Pole 120 Vac Common Trip Requires Two 1-Inch (25.4 mm) Spaces				2-Pole 240 Vac Common Trip Requires Two 1-Inch (25.4 mm) Spaces			2-Pole 240 Vac Requires Two 1-Inch (25.4 mm) Spaces		
With Isolated Line Terminals for Separately Metered Water Heaters			With Switching Neutral Pole for Gasoline Pump Applications				Where Voltage to Ground is 240 Vac			For Use as Disconnect Contains No Magnetic or Thermal Trip Properties		
5 per Shelf Carton			5 per Shelf Carton			5 per Shelf Carton			5 per Shelf Carton			
10,000 AIC			10,000 AIC			10,000 AIC			5,000 AIC			
Ampere Rating	Catalog Number	Price U.S. \$	Ampere Rating	Catalog Number	Price U.S. \$	Ampere Rating	Catalog Number	Price U.S. \$	Ampere Rating	Catalog Number	Price U.S. \$	
15	BRWH215		15	BRSN215		#14 – 4	10	BR210H		—	—	
20	BRWH220		20	BRSN220			15	BR215H		—	—	
30	BRWH230		25	BRSN225			20	BR220H		—	—	
—	—		30	BRSN230			25	BR225H		—	—	
—	—		—	—			30	BR230H		—	—	
—	—		—	—			35	BR235H		—	—	
—	—		—	—			40	BR240H		—	—	
—	—		—	—			45	BR245H		—	—	
—	—		—	—			50	BR250H		50	BR250NA	
—	—		—	—			55	BR255H		—	—	
—	—		—	—		#4 – 1/0	60	BR260H		60	BR260NA	
—	—		—	—			70	BR270H		—	—	
—	—		—	—			80	BR280H		—	—	
—	—		—	—			90	BR290H		—	—	
—	—		—	—			100	BR2100H		100	BR2100NA	

Discount Symbol 22CD

Circuit Breaker Accessories



3

Table 3-124. Field Installation Kits and Parts

Description	Ordering Quantity ①	Catalog Number	Price U.S. \$ Each
Handle Ties ② Handle tie bar for physically joining the handles of two adjacent 1-pole Type BR Circuit Breakers. (Metal Cylinder Pin Type)	10	BHT	
Handle tie bar for joining two independent outside poles of Types BQ and BQC Quadplex and outside poles of two Type BD Duplex Circuit Breakers.	10	THOW	
Handle tie bar for joining two adjacent outside poles of Types BQ and BQC Quadplex and outside poles of two Type BD Duplex Circuit Breakers.	10	THS1	
Handle Lockoffs ③④ Padlockable device for locking the handle of 1-, 2- or 3-pole Type BR Circuit Breakers and 1-pole of a Type BD Duplex or one independent outside pole of a Type BQ or BQC Quadplex Circuit Breakers. (Escutcheon Mounted) ⑤	10	BRLW	
Padlockable device for locking the handle of a 1-pole Type BR Circuit Breaker. (Handle Mounted) ⑥	10	BRLW1	
Padlockable device for locking the handle of a 2- and 3-pole Type BR Circuit Breaker. (Handle Mounted) ⑥	10	BRLW2	
Padlockable device for locking the handle of a 1-pole Type BD Duplex, BQ or BQC Quadplex Breaker. (Handle Mounted) ⑥	10	BRDL1	
Padlockable device for locking the handle of the two center poles and the two outer poles of a 2-pole Types BQ and BQC Quadplex Circuit Breakers. (Escutcheon Mounted) ⑤	10	BRQLW	
Padlockable device for locking the handle of main circuit breaker Types CC and CHH into the ON or OFF position. (Screw Mounted) ⑦	1	CCPL	
Padlockable device for locking the handle of main breaker Types BW and BWH into the ON or OFF position. (Escutcheon Mounted) ⑤	1	MCBPL	
Handle Lockdogs ④⑧ Device used to secure handle in ON or OFF position for 1-, 2- or 3-pole Type BR Circuit Breakers and 1-pole of Type BD Duplex and one independent outside pole of Type BQ or BQC Quadplex Circuit Breakers. (Escutcheon Mounted) ⑤	10	BHLW	
Device used to secure handle in ON or OFF position for 1-pole Type BR Circuit Breakers. (Handle Mounted) ⑥	10	BHLW1	
Device used to secure handle in ON or OFF position for 2- and 3-pole Type BR Circuit Breakers. (Handle Mounted) ⑥	10	BHLW2	
Device used to secure handle in ON or OFF position for 1-pole Type GFCE Ground Fault Circuit Breakers. (Handle Mounted) ⑥	10	BHGW	
Device used to secure handle in ON or OFF position for one independent outside pole of Types BQ and BQC Quadplex or 1-pole Type BD Duplex Circuit Breakers. (Handle Mounted) ⑥	10	HLW1	
Hold-Down Kits ⑨ Hold-down retainer kit for 3-pole Type BR Circuit Breakers in S3100 and 3100R Loadcenters only.	1	BRHDB	
Hold-down screw kit for 2-pole Type BR Circuit Breakers in 1-phase MLO Loadcenters through 125 amperes.	1	BREQS125	
Hold-down screw kit for 2-pole Type BR Circuit Breakers in MLO Loadcenters 150 through 225 amperes (1-phase only).	1	BRHDK125	
Hold-down screw kit for 2-pole Types BJ and BJH Circuit Breakers in MLO Loadcenters 125 through 225 amperes.	1	BJHDS	
Hold-down screw kit for 3-pole Types BJ and BJH Circuit Breakers in MLO Loadcenters 125 through 225 amperes.	1	BJHDS3P	
Main Breaker Lug Kits Types CC and CHH Main Breaker Lug Kit (2) 300 kcmil.	1	CCL300	
Types BW/BWH Main Breaker Lug Kit (2) 300 kcmil.	1	MCBL300	
Mechanical Interlocks Types BR for 2-, 3- and 4-pole breakers.	10	BRML	

① Must be purchased in multiples of ordering quantities indicated.
 ② Handle Ties: Typically used to join two similar independent single-pole breakers to form a 2-pole noncommon trip breaker.
 ③ Handle Lockoffs: Devices that use a padlock to lock the circuit breaker's handle in the "On" or "Off" position.
 ④ See Table 3-126 for Handle Position Changeability Chart.
 ⑤ Escutcheon Mounted: Device mounted semipermanently to the face of the circuit breaker and secured by the loadcenter deadfront.
 ⑥ Handle Mounted: Device mounted directly to the handle by the use of a set screw.
 ⑦ Screw Mounted: Device permanently mounted to the face of the circuit breaker by the use of a non-removable screw.
 ⑧ Handle Lockdogs: Devices that are used to secure a circuit breaker's handle in the "On" or "Off" position. Handle Lockdogs are not padlockable devices.
 ⑨ Hold-Down Kits: Devices used to secure the circuit breaker to the loadcenter for back-feed main application. See NEC Article 384-16(g).

Discount Symbol **22CD**

Circuit Breaker Accessories

3

Table 3-125. Shunt Trips, Auxiliary and Alarm Contacts

Description	Catalog Number ^① Suffix Adder	Price U.S. \$ ^② Adder Each
Shunt Trip for Types BW/BWH		
12 Volts	SR12	
24 Volts	SR24	
120 Volts	SR01	
Shunt Trip for Types BR		
120 Volts	ST	
Auxiliary Contact for Types BW/BWH		
(1) NO and (1) NC	AL1	
(2) NO and (2) NC	AL2	
Alarm Contacts for Types BW/BWH		
Types BW/BWH	CR1	
Alarm Contacts for Type GFCB (1-Pole)		
Alarm Contact for GFCB (1-Pole)	W1	
(1) NO and (1) NC	W2	

① Add suffix indicated to end of breaker catalog number.
 ② Add amount shown to circuit breaker list price.

Table 3-126. Handle Position Changeability Chart

Handle Lockoff and Lockdog Types	To Change Handle Position from "On to "Off," or "Off" to "On" You Must...		
	Remove Padlock	Remove Device	Remove Loadcenter Deadfront
Lockoff Escutcheon Mounted	Remove	—	—
Lockoff Handle Mounted	Remove	Remove	—
Lockoff Screw Mounted	Remove	—	—
Lockdog Escutcheon Mounted	N/A	Remove	Remove
Lockdog Handle Mounted	N/A	Remove	—

Technical Data and Specifications

Residential/Commercial/New York City Loadcenters, Unit Enclosures — Box Sizes

Note: Box sizes do not include covers/fronts.

Table 3-127. Residential Loadcenters — NEMA Type 1 Indoor

Box Size	Dimensions in Inches			Dimensions in mm		
	Height	Width	Depth	Height	Width	Depth
A1	15.00	11.25	3.75	381.0	285.8	95.3
B1	16.75	14.31	3.88	425.5	363.5	98.4
B2	18.75	14.31	3.88	476.3	363.5	98.4
C1	21.00	14.31	3.88	533.4	363.5	98.4
C2	23.00	14.31	3.88	584.2	363.5	98.4
C4	27.00	14.31	3.88	685.8	363.5	98.4
D1	29.13	14.31	3.88	739.8	363.5	98.4
G1	34.13	14.31	3.88	866.8	363.5	98.4
L1	39.00	14.31	3.88	990.6	363.5	98.4
L2	45.00	14.31	3.88	1143.0	363.5	98.4
2	8.63	5.00	3.50	219.1	127.0	88.9
3	9.44	4.50	3.00	239.7	114.3	76.2
4	13.00	11.00	3.56	330.2	279.4	90.5
5	9.44	4.50	3.00	239.7	114.3	76.2
6	12.00	6.88	4.50	304.8	174.6	114.3
7	13.00	11.00	3.56	330.2	279.4	90.5
9	14.50	6.50	3.50	368.3	165.1	88.9

Table 3-128. Residential Loadcenters — NEMA Type 3R Outdoor

Box Size	Dimensions in Inches			Dimensions in mm		
	Height	Width	Depth	Height	Width	Depth
B1R	16.75	14.31	5.19	425.5	363.5	131.8
B2R	18.75	14.31	5.19	476.3	363.5	131.8
C3R	25.00	14.31	5.19	635.0	363.5	131.8
D1R	29.13	14.31	5.19	739.8	363.5	131.8
G1R	34.13	14.31	5.19	866.8	363.5	131.8
L1R	39.00	14.31	5.19	990.6	363.5	131.8
L2R	45.00	14.31	5.19	1143.0	363.5	131.8
2R	8.63	5.00	3.50	219.1	127.0	88.9
3R	9.44	4.50	3.00	239.7	114.3	76.2
4R	13.00	11.00	3.56	330.2	279.4	90.5
5R	9.44	4.50	3.00	239.7	114.3	76.2
6R	11.75	6.50	4.50	298.5	165.1	114.3
7R	13.00	11.00	3.56	330.2	279.4	90.5
8R	27.00	10.50	4.75	685.8	266.7	120.7
9R	14.25	6.50	4.00	362.0	165.1	101.6
C1R	21.00	14.31	5.19	533.4	363.5	131.8

Table 3-129. Commercial Loadcenters — NEMA Type 1 Indoor

Box Size	Dimensions in Inches			Dimensions in mm		
	Height	Width	Depth	Height	Width	Depth
19	44.00	16.16	6.25	1117.6	410.4	158.8
20	44.00	16.16	6.25	1117.6	410.4	158.8
22	54.00	16.22	6.31	1371.6	412.0	160.3
24	66.50	16.22	6.31	1689.1	412.0	160.3

Table 3-130. Commercial Loadcenters — NEMA Type 3R Outdoor

Box Size	Dimensions in Inches			Dimensions in mm		
	Height	Width	Depth	Height	Width	Depth
42	38.00	16.31	6.38	965.2	414.3	161.9
43	44.00	16.31	6.38	1117.6	414.3	161.9
46	54.00	16.31	6.38	1371.6	414.3	161.9
47	66.56	16.31	6.38	1690.7	414.3	161.9

Table 3-131. New York City Loadcenters — NEMA Type 1 Indoor

Box Size	Dimensions in Inches			Dimensions in mm		
	Height	Width	Depth	Height	Width	Depth
A	38.00	18.13	5.00	965.2	460.4	127.0
B	44.00	18.13	5.00	1117.6	460.4	127.0
C	66.50	18.13	6.25	1689.1	460.4	158.8

Table 3-132. Types ECB and ECC Unit Enclosures — NEMA Type 1 Indoor

Dimensions in Inches			Dimensions in mm		
Height	Width	Depth	Height	Width	Depth
23.25	8.88	4.50	590.6	225.4	114.3

Table 3-133. Types ECB and ECC Unit Enclosures — NEMA Type 3R Outdoor

Dimensions in Inches			Dimensions in mm		
Height	Width	Depth	Height	Width	Depth
23.68	9.31	5.44	601.7	236.5	138.1

3

Residential Loadcenter Knockouts — Dimensions in Inches (mm)

3

Knockouts for Box Sizes A1, B1, B2, C1, C2, C4, D1, G1, L1, L2, B1R, B2R, C1R C3R, D1R, G1R, L1R, L2R

Code	Diameter in Inches					Diameter in mm				
A	.50	.75	—	—	—	12.7	19.1	—	—	—
B	.50	—	—	—	—	12.7	19.1	—	—	—
C	.50	1.25	1.50	2.00	2.50	12.7	31.8	38.1	50.8	63.5
D	1.25	1.25	2.00	2.50	—	31.8	38.1	50.8	63.5	—
E	.50	.75	1.00	—	—	12.7	19.1	25.4	—	—
F	.50	.75	1.00	1.50	2.00	12.7	19.1	25.4	38.1	50.8
G	1.25	1.50	2.00	—	—	31.8	38.1	50.8	—	—
H	.50	.75	1.00	1.25	1.50	12.7	19.1	25.4	31.8	38.1
I	1.00	1.25	1.50	2.00	2.50	25.4	31.8	38.1	50.8	63.5
J	1.00	1.25	1.50	—	—	25.4	31.8	38.1	—	—

Knockouts for Box Sizes 3, 4, 5, 6, 7, 9, 2R, 3R, 4R, 5R, 6R, 7R, 8R, 9R

Code	Diameter in Inches					Diameter in mm				
A	.50	—	—	—	—	12.7	—	—	—	—
B	.50	.75	—	—	—	12.7	19.1	—	—	—
C	.50	.75	1.00	—	—	12.7	19.1	25.4	—	—
D	.50	.75	1.00	1.25	1.25	12.7	19.1	25.4	31.8	—
E	.75	1.00	1.25	—	—	19.1	25.4	31.8	—	—
F	.75	1.00	1.25	1.50	1.50	19.1	25.4	31.8	38.1	—
G	1.00	1.25	1.50	—	—	25.4	31.8	38.1	—	—
H	1.00	1.25	1.50	2.00	2.00	25.4	31.8	38.1	50.8	—
I	1.25	1.50	2.00	—	—	31.8	38.1	50.8	—	—

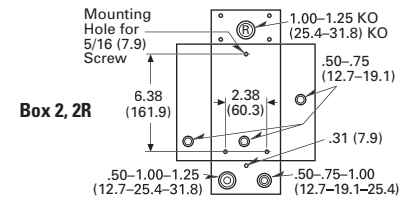

Outdoor Boxes
B1R, B2R, C1R
C3R, D1R, G1R,
L1R, L2R

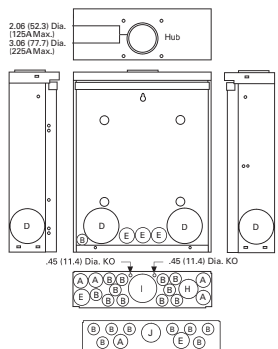

Indoor Boxes
A1

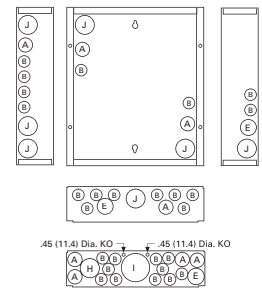

Indoor Boxes
B1, B2

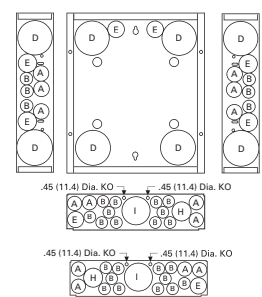

Indoor Boxes
C1, C2, C4, D1,
G1, L1, L2

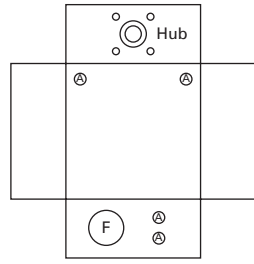
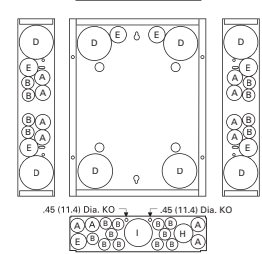

Box 3R

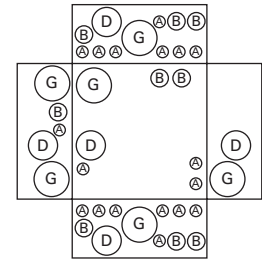

Box 4

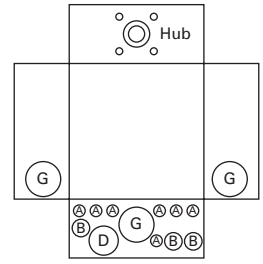

Box 4R

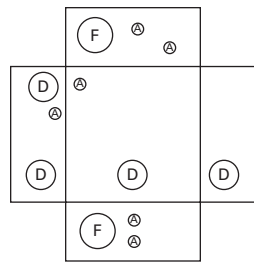

Box 5

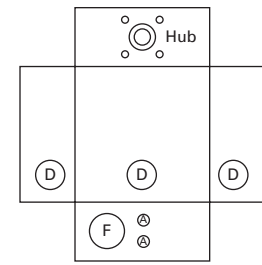

Box 5R

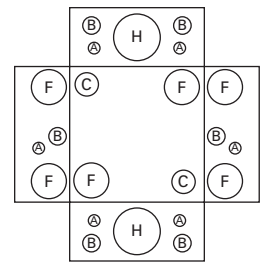

Box 6

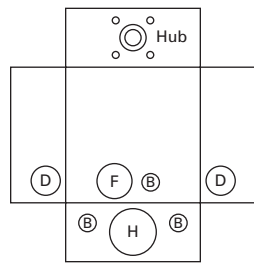

Box 6R

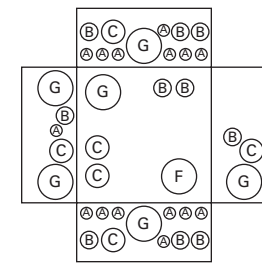

Box 7

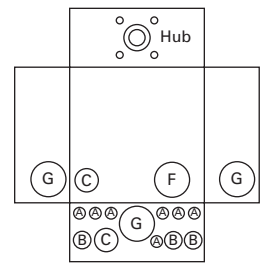

Box 7R

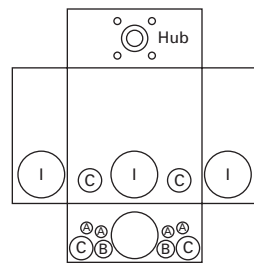

Box 8R

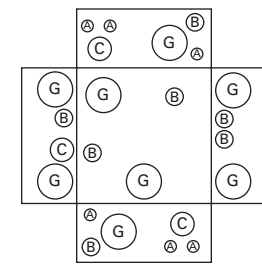

Box 9

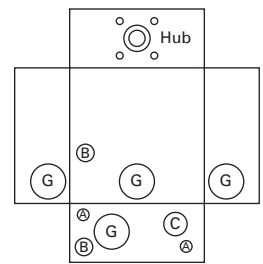

Box 9R

Figure 3-27. Residential NEMA Type 1 Indoor and NEMA Type 3R Outdoor Enclosures

Loadcenter Cross-Reference

Cross-Reference

Table 3-137. Loadcenter Cross-Reference

3/4-Inch (19.1 mm) Loadcenters		1-Inch (25.4 mm) Loadcenters			
Cutler-Hammer — CH ①	Square D® — QO ①	Cutler-Hammer — BR ②	Siemens® ①	GE® — PowerMark Plus™/Gold™ ②	Square D — HOMELINE® ②
Main Lug Loadcenters					
CH2L125RP CH4L125RP CH8L125SP	— — —	BR24L125RP BR48L125RP BR816LC125SDP ①	— W0408ML1125 ② E0816ML1125FCU	TPL212R ② TL412R1 ② TLM812S1 ②	— — —
CH8L125RP CH12L125B CH12L125R	— QO112L125G QO112L125GRB	BR816L125RP BR1212L125 BR1224L125R	W0816ML1125SCU G1212ML1125CU W1212ML1125CU	TLM812R ② TLM1212CCU TLM1212RCU	— — —
CH16L125B CH20L125C CH24L125C	QO116L125G QO120L125G QO124L125G	BR1624L125 BR2024L125 BR2424L125	G1616ML1125CU G2020ML1125CU G2424ML1125 ②	TLM1612RCCU TLM2412CCU TLM2412CCU	HOM16-24L125C HOM20-24L125TC —
CH32L150D CH32L225D CH24L3125C	QO130L150G — QO324L125G	— — —	— — —	— — —	— — —
CH42L225G CH42L3225G —	QO142L225G QO342M225 —	BR4242L225 3BR4242L225 BR1224L125	G4242ML1225CU G4242ML3225CU G1224ML1125 ②	TLM4222CCU TL42422C ② TLM1212CCU	— — —
— — —	— — —	BR1224L125G BR3040L200 BR4040L200 3BR4242L200	— G3040ML1200 ② G4040ML1200 ② G4242ML3200CU	TLM1212CG ② — TLM4020CCU TL42420C	HOM12-24L125TC HOM3040L200TC HOM40L200C —
Main Breaker Loadcenters					
CH8B200RF CH22B100C CH22B100R	QO18-16M200FTRB QO20M100 QO20M100RB	BR816B200RF BR2020B100 BR2024B100R	W0816ML1200CT G2020MB1100CU W2020MB1100CU	TM820RCUFL TM2010CCU TM2010RCU	HOM8-16M200FTRB HOM20M100C HOM20M100RB
CH32B150J CH32B150R CH32B200J	QO30M150RB QO30M150RB QO30M200	BR3030B150 BR3030B150R BR3040B200	G3030MB1150CU W3030MB1150CU G3030MB1200CU	TM3215CCU TM3215RCU TM3220CCU	HOM30M150C HOM30M150RB HOM30-40M200TC
CH32B200R CH42B200R CH42B200K	QO30M200RB QO40M200RB QO40M200	BR3040B200R BR4040B200R BR4040B200	W3030MB1200CU W4040MB1200CU G4040MB1200CU	TM3220RCU TM4020RCU —	— HOM40M200RB HOM40M200C
CH30B3200L CH42B3200L —	QO330M200 QO342M200 —	3BR3042B200 3BR4242BC200 ① BR48B200RF	G3042MB3200CU G4242MB3200CU —	TM30420C ② TM42420C ② —	— — —
— — —	— — —	BR1220B100 BR2040B200 BR2040B200R	G1224MB1100 ② G2040MB1200 ② —	TM1210CCUG TM2020CCU TN2020RCU	HOM12-24M100TC HOM20-40M200C —
— — —	— — —	BR3030B150 3BR3042B200 3BR4242DSN	G3030MB1150 ② — —	TM3215CCU — TM42440S ②	HOM30M150C — —

① Copper bus unless otherwise specified.

② Aluminum bus unless otherwise specified.

Note: These products are by no means equivalent but functionally similar. There are differences in the number of circuits and/or conductor material. This is a cross-reference tool not an interchangeability chart.

Circuit Breakers Cross-Reference

Table 3-138. Circuit Breakers

3/4-Inch Breakers (19.1 mm)		1-Inch Breakers (25.4 mm)			
CH Breakers	Square D — QO	BR Breakers	Siemens	GE	Square D — HOMELINE
CH115 CH120 CH130	QO115 QO120 QO130	BR115 BR120 BR130	Q115 Q120 Q130	THQL1115 THQL1120 THQL1130	HOM115 HOM120 —
CH210 CH2100 CH2125	QO210 QO2100 QO2125	— BR2100 BR2125	— Q2100 Q2125	— THQL21110 THQL21125	— HOM2100 HOM2125
CH215 CH220 CH225	QO215 QO220 QO225	BR215 BR220 BR225	Q215 Q220 Q225	THQL2115 THQL2120 THQL2125	HOM215 HOM220 HOM225
CH230 CH240 CH250	QO230 QO240 QO250	BR230 BR240 BR250	Q230 Q240 Q250	THQL2130 THQL2140 THQL2150	HOM230 HOM240 HOM250
CH260 CH270 CH280	QO260 QO270 QO280	BR260 BR270 BR280	Q260 Q270 Q280	THQL2160 THQL2170 THQL2180	HOM260 HOM270 —
CH3100 CH320 CH330	QO3100 QO320 QO330	BR3100 BR320 BR330	Q3100 Q320 Q330	THQL32100 THQL32020 THQL32030	— — —
CH340 CH350 CH360	QO340 QO350 QO360	BR340 BR350 BR360	Q340 Q350 Q360	THQL32040 THQL32050 THQL32060	— — —
CHNT1515 CHNT2020	— —	BR1515 BR2020	— —	— —	— —
CHQ120 CHQ230	QO120 QO230	— —	— —	— —	— —
CHT1515 CHT1520 CHT2020	QOT1515 — QOT2020	BD1515 BD1520 BD2020	Q1515 Q1520 Q2020	— — —	HOMT1515 HOMT1520 HOMT2020
CHQ120 CHQ230 —	QO120 QO230 —	— — BQ230240	Q120 Q230 —	TQ1120 TQ2130 —	— — —
— —	— —	BQ220230 BD3020	Q23020 Q2030	— —	— —

Note: These products are by no means equivalent but functionally similar. This is a cross-reference tool not an interchangeability chart.

Table 3-139. Ground Fault Breakers

3/4-Inch Breakers (19.1 mm)		1-Inch Breakers (25.4 mm)			
CH Breakers	Square D — QO	BR Breakers	Siemens	GE	Square D — HOMELINE
CH115GF CH120GF CH220GF	QO115GFI QO120GFI QO220GFI	GFCB115 GFCB120 GFCB220	QF115 QF120 QF220	THQL1115GF THQL1120GF THQL2120GF1	HOM115GFI HOM120GFI HOM220GFI
CH230GF CH240GF CH250GF CH260GF	QO230GFI QO240GFI QO250GFI QO260GFI	GFCB230 GFCB240 GFCB250 —	QF230 QF240 QF250 QF260	THQL2130GF1 THQL2140GF1 THQL2150GF1 —	HOM230GFI HOM240GFI HOM250GFI —

Type CHQ

UL Classified Circuit Breakers

Cutler-Hammer UL classified Replacement Circuit Breakers by Eaton Corporation are available in both 3/4-inch Type CHQ and 1-inch Type CL, 1- and 2-pole configurations. These breakers are classified as direct replacements by Underwriters Laboratories. In addition to a UL listing, they also come with a 15-year warranty.

Specified vs. UL Classified

Specified breakers are listed by the manufacturer of the panelboard for use in a particular panel. This doesn't mean that the panelboard manufacturer produced the specified breaker; it merely means that the panelboard manufacturer has tested the breaker in the panel. In fact, through the years, Eaton has manufactured thousands of breakers for other panelboard manufacturers.

UL classified breakers are produced by one manufacturer for use in place of the breakers specified on the panelboard. Like specified breakers, UL classified breakers have been tested in the panels for which they are approved.

Testing

Classified breakers are tested extensively in numerous GE, Siemens, Murray®, Thomas & Betts®, Square D, and Crouse-Hinds® panels. The tests are conducted with witnesses from Underwriters Laboratories Inc. and involve short circuit, temperature, and insertion/withdrawal applications. This level of testing assures that the breakers meet identified standards and have been found suitable by UL for the specified purpose.

Understanding Classified Breaker Terminology

Definitions

Specified Circuit Breaker — Each manufacturer lists the brands of circuit breakers that can be used in their panelboards. Often, manufacturers will not list competitors as specified, even though they are suitable replacements.

Classified Circuit Breaker — A breaker that is considered suitable, by a qualified third party organization, for use in another manufacturer's panelboard.

Listed Breaker — The listing of a circuit breaker is by an independent third party. Cutler-Hammer classified breakers are listed by UL.

Labeled Breaker — A breaker with a label affixed by an independent third party.

Type CHQ Replacement Breakers for Square D Type QO Loadcenters

10,000 Amperes Interrupting Capacity
120 and 120/240 Vac



CHQ120 CHQ230

Table 3-140. Type CHQ Classified Breakers 3/4-Inch (19.1 mm) per Pole 120 or 120/240 Vac, 10 kAIC

Ampere Rating	Wire Size Range Cu/Al 60°C or 75°C	1-Pole 120/240 Vac	2-Pole 120/240 Vac Common Trip
		Requires One 3/4-Inch (19.1 mm) Space	Requires Two 3/4-Inch (19.1 mm) Spaces
		10 per Shelf Carton	5 per Shelf Carton
		10,000 AIC	10,000 AIC
		Catalog Number	Price U.S. \$
15	(1) #14 – 8	CHQ115	CHQ215
20	(2) #14 – 10	CHQ120	CHQ220
25		CHQ125	CHQ225
30		CHQ130	CHQ230
35		CHQ135	CHQ235
40		CHQ140	CHQ240
45		CHQ145	CHQ245
50		CHQ150	CHQ250
60		—	CHQ260

Type CHQ Ground Fault and Arc Fault Replacement Breakers for Square D Type QO Loadcenters

10,000 Amperes Interrupting Capacity
120 and 120/240 Vac



CHQ115GF CHQ220GF

Table 3-141. Type CHQ Breakers — 5 Milliampere — 3/4-Inch (19.1 mm) per Pole

Ampere Rating	Wire Size Range Cu/Al 60°C or 75°C	1-Pole 120 Vac	2-Pole 120/240 Vac Common Trip
		Requires One 3/4-Inch (19.1 mm) Space	Requires Two 3/4-Inch (19.1 mm) Spaces
		10 per Shelf Carton	5 per Shelf Carton
		10,000 AIC	10,000 AIC
		Catalog Number	Price U.S. \$

Ground Fault

15	(1) #14 – 8	CHQ115GF	CHQ215GF
20	(2) #14 – 10	CHQ120GF	CHQ220GF
25		CHQ125GF	CHQ225GF
30		CHQ130GF	CHQ230GF
35		—	CHQ235GF
40		—	CHQ240GF
45		—	CHQ245GF
50		—	CHQ250GF

Arc Fault

15	—	CHQ115AF	—
20	—	CHQ120AF	—

Arc Fault/Ground Fault

15	#14 – 4	CHQ115AFGF	—
20	—	CHQ120AFGF	—

Table 3-142. Type CHQ Surge Arrester

Catalog Number	Price U.S. \$
CHQSA	

Table 3-143. CHQ Breaker Accessories

Description	Catalog Number	Price U.S. \$
Breaker Handle Lock	CHLO	

Discount Symbol **22GD**

Type CL

Type CL Replacement Breakers for Square D HOMELINE, General Electric, Crouse-Hinds, Thomas & Betts, Murray and ITE®/Siemens Loadcenters



CL



CLAF



CLR

Table 3-144. Type CL Breakers, 1-Inch (25.4 mm) per Pole

Ampere Rating	Wire Size Range Cu/Al 60°C or 75°C	1-Pole 120/240 V Requires One 1-Inch (25.4 mm) Space		2-Pole 120/240 V Common Trip Requires Two 1-Inch (25.4 mm) Spaces	
		10 per Shelf Carton		5 per Shelf Carton	
		10 kAIC		10 kAIC	
		Catalog Number	Price U.S. \$	Catalog Number	Price U.S. \$
15	#14 – 4	CL115		CL215	
20		CL120		CL220	
25		CL125		CL225	
30		CL130		CL230	
35		CL135		CL235	
40		CL140		CL240	
45		CL145		CL245	
50	CL150	CL250			

Table 3-145. Type CL Classified Arc and Ground Fault Breakers (5 Milliamper), 1-Inch (25.4 mm) per Pole

Ampere Rating	Wire Size Range Cu/Al 60°C or 75°C	1-Pole 120/240 V Requires One 1-Inch (25.4 mm) Space	
		1 per Shelf Carton	
		10 kAIC	
		Catalog Number	Price U.S. \$
15	#14 – 4	CL115AF	
20		CL120AF	
15	#14 – 4	CL115AFGF	
20		CL120AFGF	
15	#14 – 4	CL115GF	
20		CL120GF	
30		CL130GF	

Arc Fault Breakers

15	#14 – 4	CL115AF	
20		CL120AF	

Arc Fault/Ground Fault Breakers

15	#14 – 4	CL115AFGF	
20		CL120AFGF	

Ground Fault Breakers

15	#14 – 4	CL115GF	
20		CL120GF	
30		CL130GF	

Table 3-146. Type CL Classified Latching Remote Control Smart Breakers™, 1-Inch (25.4 mm) per Pole

Ampere Rating	Wire Size Range Cu/Al 60°C or 75°C	1-Pole 120 V Requires One 1-Inch (25.4 mm) Space		2-Pole 120/240 V Common Trip Requires Two 1-Inch (25.4 mm) Spaces	
		10 per Shelf Carton		5 per Shelf Carton	
		10 kAIC		10 kAIC	
		Catalog Number	Price U.S. \$	Catalog Number	Price U.S. \$
15	(2) #14 – 10	CLRP115		CLRP215	
20	(1) #8 – 6	CLRP120		CLRP220	
25		CLRP125		CLRP225	
30		CLRP130		CLRP230	

Application Notes

Technical Data

Arc Fault Application Notes

An arc fault circuit interrupter is a device intended to provide protection from the effects of arc faults by recognizing characteristics unique to arcing and by functioning to de-energize the circuit when the arc fault is detected. As of January 1, 2002, the National Electrical Code (NEC) now requires all branch circuits that supply 125 volt, single-phase, 15 and 20 ampere receptacle outlets installed in dwelling unit bedrooms shall be protected by an arc fault circuit interrupter(s). This includes ceiling lighting (recessed, ceiling fans, etc.) as well as smoke detectors and all other bedroom outlets. The 2005 NEC introduced the application of the Combination Type AFCI for bedroom circuits required as of January 1, 2008. The 2008 NEC expands this application to other living areas.

Ground Fault Application Notes

Single-pole GFCBs are designed for use in 2-wire, 120 Vac circuits. **Figure 3-33** shows a typical wiring configuration.

Two-pole GFCBs are designed for use in 3-wire, 120/240 Vac circuits, 120 Vac multiwire circuits employing common, neutral and 2-wire, 240 Vac circuits obtained from a 120/240 Vac source.

Figure 3-34 and **Figure 3-37** illustrate typical wiring configurations for 120/240 Vac multiwire circuits.

Figure 3-38 depicts a 240 Vac, 2-wire circuit. Note the "panel neutral" conductor connects to the neutral bar, even though the neutral is not included in the load circuit. This connection is necessary to supply a 120 Vac power source to the ground fault sensing circuit.

The figures are shown with a 120/240 Vac, single-phase, 3-wire power source, but are also applicable to a 120/208 Vac, 3-phase, 4-wire power supply. For all figures, the electrical operation of the GFCB is not affected by the equipment ground.

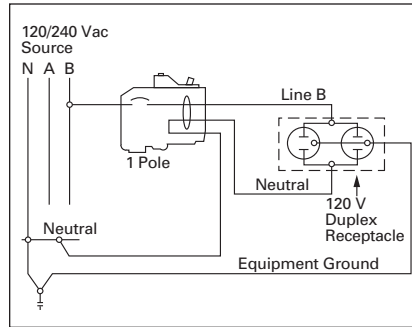

Figure 3-31. 1-Pole 120 Volt Load Application Sourced by 120/240 Vac

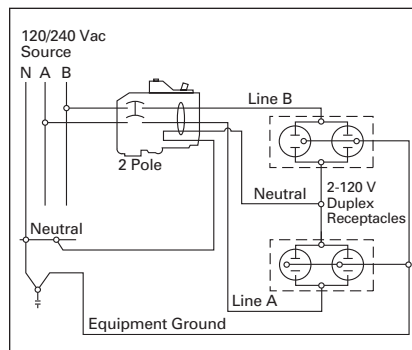

Figure 3-32. 2-Pole Shared Neutral with Multi-Duplex Receptacle Application

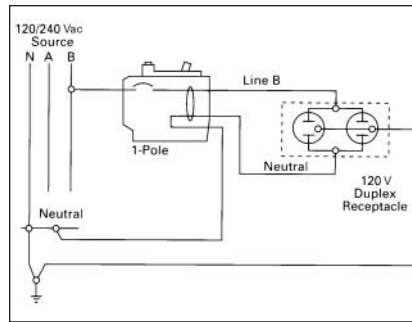

Figure 3-33. 1-Pole 120 Volt Duplex Receptacle Application

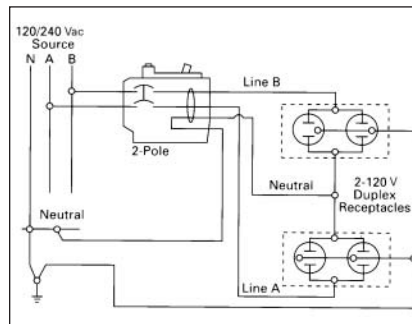

Figure 3-34. 2-Pole 120 Volt Multi-Duplex Receptacle Application

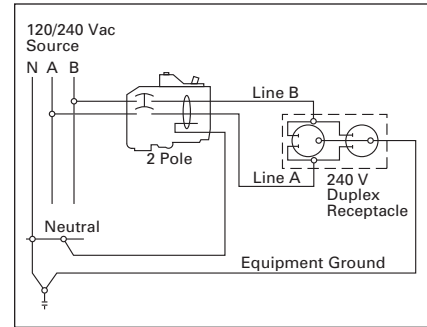

Figure 3-35. 2-Pole 240 Volt Load Application Sourced by 120/240 Vac

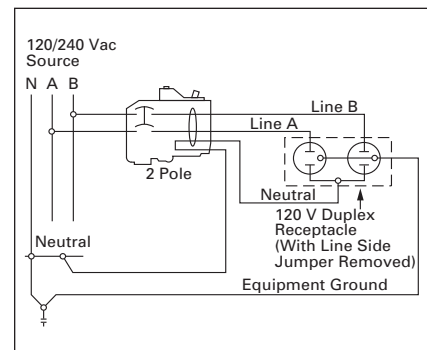

Figure 3-36. 2-Pole Shared Neutral with Duplex Receptacle Application

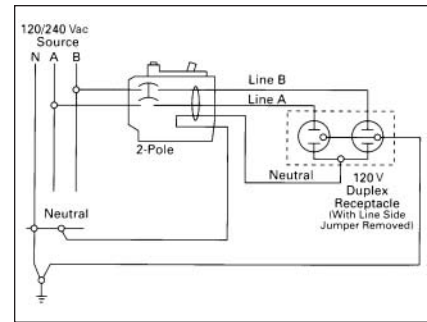

Figure 3-37. 2-Pole 120 Volt Duplex Receptacle Application

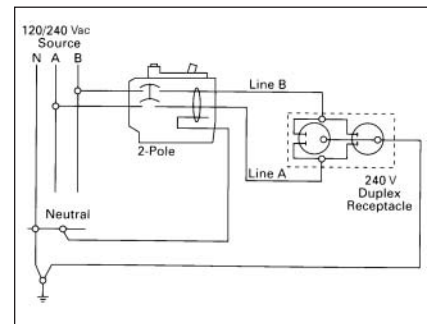

Figure 3-38. 2-Pole 240 Volt Duplex Receptacle Application

Product Description

OEM Loadcenter Interiors

Product Description

As a leader in the electrical distribution equipment business, Eaton has a unique product offering for equipment manufacturers, panel builders and virtually any OEM that has a need for power distribution within their equipment. The OEM interior offering consists of a wide variety of power distribution options utilizing components from Cutler-Hammer CH and BR Loadcenter product lines. With high-volume, standardized products, OEMs can expect to receive high-quality products covering configurations meeting virtually any power distribution need.

Coupled with Eaton's expertise in circuit breaker design and manufacturing, our OEM interiors provide solid power distribution and circuit protection in a compact, easy-to-install package. Interiors are offered from 2 to 42 circuits and from 70 to 225 amperes.

Quality

Built in our ISO 9002 certified manufacturing facilities, customers can be assured of the process quality in place for the manufacture of these products. Utilizing the latest in computer-controlled plating, painting, molding, stamping and welding processes, our customers have come to expect consistent high-quality from shipment to shipment.

Two Products Offer Design Flexibility

As a manufacturer of two lines of loadcenters, we are in a unique position to offer the broadest range of interiors in the market. Each line has its own unique characteristics that appeal to various segments of the market. OEM interiors are UL recognized components and are listed in either of the following UL files: E8741 or E52977.

The CH interiors feature 100% copper bus and use the CH 3/4-inch (19.1 mm) wide circuit breaker, which minimizes panel space. Recognized by contractors for its sturdy design, the CH interior will appeal to those customers seeking an industrial quality bolted bus bar and the space saving of 3/4-inch (19.1 mm) per bus stab. With a typical 12 circuit CH interior, this space savings amounts to an inch and a half savings over its 1-inch (25.4 mm) counterparts. The stab rating of the CH interiors is 140 amperes maximum meaning that the handle rating of breakers mounted across from one another may not exceed 140 amperes.

The BR interiors are manufactured of formed, plated aluminum or copper, and use the Cutler-Hammer Type BR 1-inch (25.4 mm) wide circuit breaker. This design affords customers the most circuit flexibility as many of these interiors allow the installation of standard 1- and 2-pole breakers as well duplex (2 poles in a 1-inch (25.4 mm) space) or quadplex (4 poles in a 2-inch (50.8 mm) space) breakers. The stab rating of the BR interiors is 200 amperes maximum, meaning that the handle rating of the breakers that are mounted across from one another may not exceed 200 amperes.

The interiors are designed for either horizontal (single-row breaker mounting), or vertical (double-row breaker mounting). To comply with National Electrical Code (NEC) requirements, if mounted horizontally, when the breaker is "ON," the handle should be in the UP position. When mounted vertically, the handle toggles from left to right, so this is not a concern.

Standards and Certifications

Class CTL

National Electrical Code Paragraph 384-15 requires branch circuit panelboards to be provided with physical means to prevent the installation of more overcurrent devices than that number of which the enclosure was designed, rated and approved. Class CTL Duplex, Quadplex and twin breakers (identified by a catalog number prefix BD, BQ, BQC and CHT) are equipped with a UL listed rejection tab over the line terminal. All OEM interiors have appropriately notched stabs to accept these rejection tab Class CTL breakers.

Duplex, Quadplex and twin breakers manufactured without the rejection tab (identified by a catalog number prefix BR, BRD and CHNT) are available for replacement purposes in older interiors.

Federal Specifications

All loadcenter enclosures meet Federal Specifications W-P-115b, Type 1, Class 2 requirements.

All 120/240 volt breakers, both 1-inch (25.4 mm), 1/2-inch (12.7 mm) and 3/4-inch (19.1 mm) per pole meet the requirement of Federal Specifications W-C 375B/Gen Type 1.

Canadian Standards Association Listing

All 1-pole and 2-pole, 120/240 volt breakers, both 1-inch (25.4 mm), 1/2-inch (12.7 mm) and 3/4-inch (19.1 mm) per pole, 225 ampere maximum, are listed as Certified by the Canadian Standards Association, Guide No. 69-11.19, Class 1432, File 18328.

Underwriters Laboratories Listing

All grounding bars manufactured comply with Underwriters Laboratories standards and are listed under Guide No. DHJR, File E31424, Volume W, Section 17.

All circuit breakers 10 amperes and larger comply with the Underwriters Laboratories "Standard for Branch Circuit and Service Circuit-Breakers" UL 489; Guide No. 60 10.2 File E31424, and "Requirements for Wire Connectors and Soldering Lugs," UL 486B, Guide No. 461 10-C File E7830.

All Cutler-Hammer breakers where marked, are suitable for use with 60/75°C rated wire, unless otherwise specified.

All devices comply with the 22 kAIC – 10 kAIC UL series connected components File DKSY2 of the Recognized Components Index.

Lighting and Appliance Panelboards

Lighting and appliance branch circuit panelboards are defined in NEC (Article 384) as "One having more than 10 percent of its overcurrent devices rated 30 amperes or less for which neutral connections are provided." Article 384 also limits the number of overcurrent devices (branch circuit poles) to a maximum of 42 in any one cabinet. When the 42 poles are exceeded, two or more separate panels are required.

For more details and engineering drawings, see BR.31.02.S.E.

Product Description

OEM Loadcenter Interiors

Table 3-147. Type CH Loadcenter Interior Assemblies

Ampere Rating	Maximum Number 3/4-Inch (19.1 mm)		UL File Reference	Main Terminal Size (Per Phase)	Standard Package Quantity	Catalog Number	Price U.S. \$
	Spaces	Single Poles					
Single-Phase Single Row Breaker Mounting — Copper Bus — 120/240 Vac, 3-Wire							
70	2	4	E8741	(1) #8 – #2 AWG Cu/Al	1	CH9MB270	
Single-Phase Double Row Breaker Mounting — Copper Bus — 120/240 Vac, 3-Wire							
125	2	2	E8741	(1) 2/0 – #6 AWG Cu/Al	20	CH2L125INT	
125	4	4	E8741	(1) 2/0 – #6 AWG Cu/Al	20	CH4L125INT	
125	8	8	E8741	(1) 2/0 – #6 AWG Cu/Al	20	CH8L125INT	
125	12	12	E8741	(1) 2/0 – #6 AWG Cu/Al	20	CH12L125INT	
125	16	16	E8741	(1) 2/0 – #6 AWG Cu/Al	20	CH16L125INT	
200	12	12	E8741	(1) 300 kcmil – #4 Cu/A	20	CH12L200INT	
200	16	16	E8741	(1) 300 kcmil – #4 Cu/Al	10	CH16L200INT	
225	24	24	E8741	(1) 300 kcmil – #4 Cu/Al	10	CH24L225INT	
225	32	32	E8741	(1) 300 kcmil – #4 Cu/Al	10	CH32L225INT	
225	42	42	E8741	(1) 300 kcmil – #4 Cu/Al	10	CH42L225INT	
Three-Phase Double Row Breaker Mounting — Copper Bus — 208Y/120 Vac, 4-Wire — 240 Vac, 3-Wire — 120/240 Vac, 4-Wire Delta							
125	12	12	E8741	(1) 2/0 – #6 AWG Cu/Al	10	CH12L3125INT	
125	18	18	E8741	(1) 2/0 – #6 AWG Cu/Al	10	CH18L3125INT	
125	24	24	E8741	(1) 2/0 – #6 AWG Cu/Al	10	CH24L3125INT	
225	24	24	E8741	(1) 300 kcmil – #4 Cu/Al	10	CH24L3225INT	
225	30	30	E8741	(1) 300 kcmil – #4 Cu/Al	10	CH30L3225INT	
225	42	42	E8741	(1) 300 kcmil – #4 Cu/Al	10	CH42L3225INT	

Table 3-148. Type BR Loadcenter Interior Assemblies

Ampere Rating	Maximum Number 1-Inch (24.5 mm)		UL File Reference	Main Terminal Size (Per Phase)	Standard Package Quantity	Catalog Number	Price U.S. \$
	Spaces	Single Poles					
Single-Phase Single Row Breaker Mounting — Aluminum Bus — 120/240 Vac, 3-Wire							
70	2	4	—	(1) #8 – #2 AWG Cu/Al	20	24INT70B	
125	2	4	E8741	(1) 1/0 – #14 AWG Cu 2/0 – 12 AWG Al	20	24INT125B	
125	6	12	E52977	(1) 2/0 – #14 AWG Cu/Al	20	612INT125SRB	
Single-Phase Double Row Breaker Mounting — Aluminum Bus — 120/240 Vac, 3-Wire							
125	4	8	E8741	(1) 2/0 – #14 AWG Cu/Al	20	48INT125B	
125	6	12	E8741	(1) 2/0 – #14 AWG Cu/Al	20	612INT125B	
125	8	16	E8741	(1) 2/0 – #14 AWG Cu/Al	20	816INT125B	
125	12	12	E52977	(1) 2/0 – #14 AWG Cu/Al	20	1212INT125B	
125	12	24	E52977	(1) 2/0 – #14 AWG Cu/Al	20	1224INT125B	
125	16	24	E52977	(1) 2/0 – #14 AWG Cu/Al	20	1624INT125B	
125	20	24	E52977	(1) 2/0 – #14 AWG Cu/Al	10	2024INT125B	
125	24	24	E52977	(1) 2/0 – #14 AWG Cu/Al	10	2424INT125B	
200	8	16	E52977	(1) 300 kcmil – #1 AWG Cu/Al	20	816INT200B	
200	12	24	E52977	(1) 300 kcmil – #1 AWG Cu/Al	20	1224INT200B	
200	30	40	E52977	(1) 300 kcmil – #1 AWG Cu/Al	10	3040INT200B	
225	42	42	E52977	(1) 300 kcmil – #1 AWG Cu/Al	10	4242INT225B	
Single-Phase Double Row Breaker Mounting — Copper Bus — 120/240 Vac, 3-Wire							
125	8	16	E52977	(1) 2/0 – #14 AWG Cu/Al	20	816INT125BC	
125	12	12	E52977	(1) 2/0 – #14 AWG Cu/Al	20	1212INT125BC	
200	12	24	E52977	(1) 300 kcmil – #1 AWG Cu/Al	20	1224INT200BC	
Three-Phase Double Row Breaker Mounting — Aluminum Bus — 208Y/120 Vac, 4-Wire — 240 Vac, 3-Wire — 120/240 Vac, 4-Wire Delta							
125	12	34	E52977	(1) 2/0 – #8 AWG Cu/Al	10	1224INT3125B	
150	18	36	E52977	(1) 300 kcmil – #2 AWG Cu/Al	10	1836INT3150B	
150	24	42	E52977	(1) 300 kcmil – #2 AWG Cu/Al	10	2442INT3150B	
200	30	42	E52977	(1) 300 kcmil – #2 AWG Cu/Al	10	3042INT3200B	
225	42	42	E52977	(1) 300 kcmil – #2 AWG Cu/Al	10	4242INT3225B	
Three-Phase Double Row Breaker Mounting — Copper Bus — 208Y/120 Vac, 4-Wire — 240 Vac, 3-Wire — 120/240 Vac, 4-Wire Delta							
125	12	24	E52977	(1) 2/0 – #8 AWG Cu/Al	10	1224INT3125BC	
200	12	24	E52977	(1) 300 kcmil – #2 AWG Cu/Al	10	1224INT3200BC	

Cutler-Hammer is a federally registered trademark of Eaton Corporation. CSA is a registered trademark of the Canadian Standards Association. Crouse-Hinds is a federally registered trademark of Cooper Industries. HOMELINE is a registered trademark of Schneider Electric. General Electric is a federally registered trademark of General Electric Company. ISO is the registered trademark and sole property of the International Organization for Standardization. ITE is a federally registered trademark of Integrated Technologies Engineering (ITE). Murray is a federally registered trademark of Siemens Energy & Automation, Inc. The National

Electrical Code and NEC are registered trademarks of the National Fire Protection Association, Quincy, Mass. NEMA is the registered trademark and service mark of the National Electrical Manufacturers Association. PowerMark Plus and PowerMark Gold are trademarks of General Electric Company. Siemens is a federally registered trademark of Siemens AG. Square D is a federally registered trademark of Schneider Electric. Thomas & Betts is a federally registered trademark of Thomas & Betts Corporation. UL is a registered trademark of the Underwriters Laboratories Inc.

Discount Symbol **22CD**